



TRANE®

*Cooling and Heating
Systems and Services*

Air-Cooled Series R™ Helical-Rotary Liquid Chiller

**Model RTAC 120 to 400
(400 to 1500 kW – 50 Hz)
Built for the Industrial and
Commercial Markets**



Model RTAC size 155

RLC-PRC005-E4

Introduction

The Trane Model RTAC Air-Cooled Helical-Rotary Chiller is the result of a search for higher reliability, higher energy efficiency, and lower sound levels for today's environment.

In an effort to reduce energy consumed by HVAC equipment and to continually produce chilled water, Trane has developed the Model RTAC chiller with higher efficiencies and a more reliable design than any other air-cooled chiller available on the market today.

The Model RTAC chiller uses the proven design of the Trane helical-rotary compressor, which embraces all of the design features that have made the Trane helical-rotary compressor liquid chillers such a success since 1987.

The RTAC offers high reliability coupled with greatly improved energy efficiency, vastly reduced physical footprint, and improved acoustical performance, due to its advanced design, low-speed, direct-drive compressor, and proven Series R™ performance.

The major advantages of the Series R, Model RTAC are:

- 99.5% reliability rate
- Smaller physical footprint
- Lower sound levels
- Higher energy efficiency
- Designed specifically for operating with environmentally-safe HFC-134a.

The Series R Model RTAC helical-rotary chiller is an industrial-grade design, built for both the industrial and commercial markets. It is ideal for schools, hospitals, retailers, office buildings, and industrial applications.

Figure 1 - Model RTAC size 350



Contents

Introduction	2
Features and Benefits	4
Options	9
Application Considerations	10
Selection Procedure	15
General Data	16
Performance Data	40
Controls	42
Wire Sizing	46
Electrical Data	48
Dimensional Data	52
Mechanical Specifications	57

Features and Benefits

The Series R™ Helical-Rotary Compressor

- Unequaled reliability. The next generation Trane helical-rotary compressor is designed, built, and tested to the same demanding and rugged standards as the Trane scroll compressors, the centrifugal compressors, and the previous generation helical-rotary compressors used in both air- and water-cooled chillers for more than 15 years.
- Years of research and testing. The Trane helical-rotary compressor has amassed thousands of hours of testing, much of it at severe operating conditions beyond normal commercial air-conditioning applications.
- Proven track record. The Trane Company is the world's largest manufacturer of large helical-rotary compressors used for refrigeration. Over 300,000 compressors worldwide have proven that the Trane helical-rotary compressor has a reliability rate of greater than 99.5% in the first year of operation—unequaled in the industry.
- Resistance to liquid slugging. The robust design of the Series R compressor can ingest amounts of liquid refrigerant that normally would severely damage reciprocating compressor valves, piston rods, and cylinders.
- Fewer moving parts. The helical-rotary compressor has only two rotating parts: the male rotor and the female rotor. Unlike reciprocating compressors, the Trane helical-rotary compressor has no pistons, connecting rods, suction and discharge valves, or mechanical oil pump. In fact, a typical reciprocating compressor has 15 times as many critical parts as the Series R compressor. Fewer moving parts leads to increased reliability and longer life.
- Direct-drive, low-speed, semi-hermetic compressor for high efficiency and high reliability.
- Field-serviceable compressor for easy maintenance.
- Suction-gas-cooled motor. The motor operates at lower temperatures for longer motor life.
- Five minute start-to-start and two minute stop-to-start anti-recycle timer allows for closer water-loop temperature control.

Features and Benefits

Improved Acoustical Performance

Sound levels are reduced significantly by addressing two major sources: the compressor and the refrigerant piping. Designed with balanced screws, an sound-absorbing casing and oversized ports, the compressor minimizes sound emission.

The three-dimensional piping concept reduces vibrations and sound level.

Superior Efficiency Levels: The Bar Has Been Raised

Trane model RTAC can propose 3 efficiency versions: standard efficiency, high efficiency and extra efficiency. RTAC can achieve EERs up to 3.17 at Eurovent conditions. The modern technology of the RTAC with the efficient direct-drive compressor, the unique evaporator design, the electronic expansion valve, and the revolutionary Tracer™ Chiller Controls, has permitted Trane to achieve these efficiency levels. Performance is subject to third party laboratory tests to obtain Eurovent certification.

Precise Rotor Tip Clearances

Higher energy efficiency in a helical-rotary compressor is obtained by reducing the rotor tip clearances. This next-generation compressor is no exception. With today's advanced manufacturing technology, clearances can be controlled to even tighter tolerances. This reduces the leakage between high- and low-pressure cavities during compression, allowing for more efficient compressor operation.

Figure 2 - Cutaway of a compressor

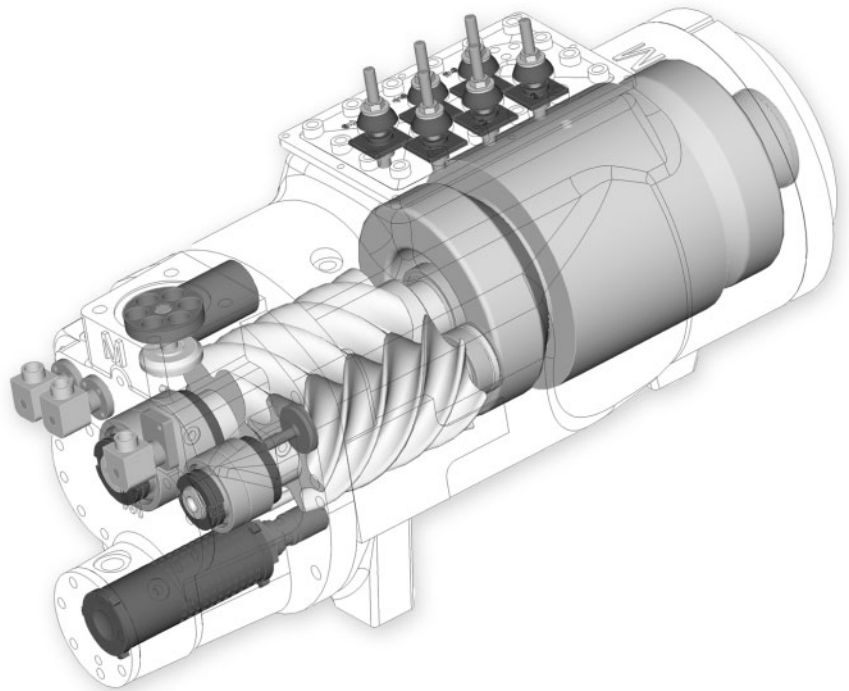

Capacity Control and Load Matching

The combination patented unloading system on Trane helical-rotary compressors uses the variable unloading valve for the majority of the unloading function. This allows the compressor to modulate infinitely, to exactly match building load and to maintain chilled-water supply temperatures within $\pm 0.3^{\circ}\text{C}$ [$\pm 0.5^{\circ}\text{F}$] of the set point. Reciprocating and helical-rotary chillers that rely on stepped capacity control must run at a capacity equal to or greater than the load, and typically can only maintain water temperature to around $\pm 1^{\circ}\text{C}$ [$\pm 2^{\circ}\text{F}$]. Much of this excess capacity is lost because overcooling goes toward removing building latent heat, causing the building to be dried beyond normal comfort requirements. When the load becomes very low, the compressor also uses a step unloader valve, which is a single unloading step to achieve the minimum unloading

point of the compressor. The result of this design is optimized part-load performance far superior to single reciprocating compressors and step-only helical-rotary compressors.

Features and Benefits

Compact Physical Size

The RTAC is one of the smallest air-cooled chillers in the industry and a prime candidate for installations that have space constraints. All physical sizes were changed without sacrificing the side clearances needed to supply fresh airflow without coil starvation—the tightest operational clearances in the industry.

Trane offers an optional reduced length version on sizes 400HE and 400XE which allows transport in a container.

Close Spacing Installation

The air-cooled Series R™ chiller has the tightest recommended side clearance in the industry, 1.2 meters, but that is not all. In situations where equipment must be installed with less clearance than recommended, which frequently occurs in retrofit applications, restricted airflow is common. Conventional chillers may not work at all. However, the air-cooled Series R chiller with the Adaptive Control™ microprocessor will make as much chilled water as possible given the actual installed conditions, stay on-line during any unforeseen abnormal conditions, and optimize its performance. Consult your sales engineer for more details.

Factory Testing Means Trouble-Free Start-up

All air-cooled Series R chillers are given a complete functional test at the factory. This computer-based test program completely checks the sensors, wiring, electrical components, microprocessor function, communication capability, expansion valve performance, and fans. In addition, each compressor is run-tested to verify capacity and efficiency. Where applicable, each unit is factory preset to the customer's design conditions. An example would be the leaving-liquid temperature set point. The result of this test program is that the chiller arrives at the job site fully tested and ready for operation.

Factory-Installed and Tested Controls and Options Speed Installation

All Series R chiller options, including main power-supply disconnect, low ambient control, ambient temperature sensor, low ambient lockout, communication interface and ice-making controls are factory installed and tested. Some manufacturers send accessories in pieces to be field installed. With Trane, the customer saves on installation expense and has assurance that ALL chiller controls and options have been tested and will function as expected.

Features and Benefits

Figure 3 - Ice storage demand cost savings

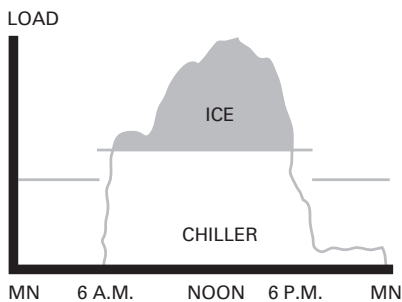

Superior Control with Tracer™ Chiller Controls

The Adaptive Control™ microprocessor system enhances the air-cooled Series R chiller by providing the very latest chiller control technology. With the Adaptive Control microprocessor, unnecessary service calls and unhappy tenants are avoided. The unit does not nuisance-trip or unnecessarily shut down. Only when the Tracer chiller controls have exhausted all possible corrective actions, and the unit is still violating an operating limit, will the chiller shut down. Controls on other equipment typically shut down the chiller, usually just when it is needed the most.

For Example:

A typical five-year-old chiller with dirty coils might trip out on high-pressure cutout on a 38°C [100°F] day in August. A hot day is just when comfort cooling is needed the most. In contrast, the air-cooled Series R chiller with an Adaptive Control microprocessor will stage fans on, modulate the electronic expansion valve, and modulate the slide valve as it approaches a high-pressure cutout, thereby keeping the chiller on line when you need it the most, on high ambient temperatures.

System Options: Ice Storage

Trane air-cooled chillers are well-suited for ice production. The unique ability to operate at decreased ambient temperature while producing ice results in approximately the same amount of work for the compressor. An air-cooled machine typically switches to ice production at night. Two things happen under this assumption. First, the leaving brine temperature from the evaporator is lowered to around -5.5 to -5°C [22 to 24°F]. Second, the ambient temperature has typically dropped about 8.3 to 11°C [15 to 20°F] from the peak daytime ambient. This effectively places a lift on the compressors that is similar to daytime running conditions. The chiller can operate in lower ambient at night and successfully produce

ice to supplement the next day's cooling demands.

The Model RTAC produces ice by supplying ice storage tanks with a constant supply of glycol solution. Air-cooled chillers selected for these lower leaving-fluid temperatures are also selected for efficient production of chilled fluid at nominal comfort-cooling conditions. The ability of Trane chillers to serve "double duty" in ice production and comfort cooling greatly reduces the capital cost of ice-storage systems. When cooling is required, ice-chilled glycol is pumped from the ice storage tanks directly to the cooling coils. No expensive heat exchanger is required. The glycol loop is a sealed system, eliminating expensive annual chemical treatment costs. The air-cooled chiller is also available for comfort-cooling duty at nominal cooling conditions and efficiencies. The modular concept of glycol ice-storage systems, and the proven simplicity of Trane Tracer™ controls, allow the successful blend of reliability and energy-saving performance in any ice-storage application.

The ice-storage system is operated in six different modes, each optimized for the utility cost at a particular time of day.

1. Provide comfort cooling with chiller
2. Provide comfort cooling with ice
3. Provide comfort cooling with ice and chiller
4. Freeze ice storage
5. Freeze ice storage when comfort cooling is required
6. Off

Features and Benefits

Tracer optimization software controls operation of the required equipment and accessories to easily move from one mode of operation to another. For example: even with ice-storage systems, there are numerous hours when ice is neither produced nor consumed, but saved. In this mode, the chiller is the sole source of cooling. For example, to cool the building after all ice is produced but before high electric all-demand charges take effect, Tracer sets the air-cooled chiller leaving-fluid set point to its most efficient setting and starts the chiller, chiller pump, and load pump.

When electrical demand is high, the ice pump is started and the chiller is either demand limited or shut down completely. Tracer controls have the intelligence to optimally balance the contribution of the ice and the chiller in meeting the cooling load.

The capacity of the chiller plant is extended by operating the chiller and ice in tandem. Tracer rations the ice, augmenting chiller capacity while reducing cooling costs. When ice is produced, Tracer will lower the air-cooled chiller leaving-fluid set point and start the chiller, ice and chiller pumps, and other accessories. Any incidental loads that persists while producing ice can be addressed by starting the load pump and drawing spent cooling fluid from the ice storage tanks.

For specific information on ice storage applications, contact your local sales office.

Options

High Efficiency/Extra Efficiency and Performance Option

These options provide oversized heat exchangers with two purposes. One, it allows the unit to be more energy efficient. Two, the unit will have enhanced operation in high-ambient conditions.

Low-Temperature Brine

The hardware and software on the unit are factory set to handle low-temperature brine applications, typically below 5°C [41°F].

Ice Making

The unit controls are factory set to handle ice making for thermal storage applications.

Tracer Summit™ Communication Interface

Permits bi-directional communication to the Trane Integrated Comfort™ system.

LonTalk® Communication Interface LCI-C

Provides the LonMark® chiller profile input/outputs for use with a generic BAS (Building Automation System)

Remote Input Options

Permits remote chilled-liquid set point, remote current-limit set point, or both, by accepting a 4-20 mA or 2-10 VDC analog signal.

Remote Output Options

Permits alarm relay outputs, ice-making outputs, or both.

Protection Grilles

Protection grilles cover the complete condensing coils and the service areas beneath the coils.

Coil Protection

A coated wire mesh that covers the condenser coils only.

Condenser Corrosion Protection

Copper fins and Black Epoxy Coated aluminium fins are available on all sizes for corrosion protection. Job site conditions should be matched with the appropriate condenser fin materials to inhibit coil corrosion and ensure extended equipment life.

Service Valves

Provides a service valve on the suction lines of each circuit to facilitate compressor servicing.

High-Ambient Option

The high-ambient option consists of special control logic to permit high-ambient (up to 52°C [125°F]) operation. This option offers the best performance when coupled with the premium efficiency and performance option.

Low-Ambient Option

The low-ambient option consists of special control logic and fans to permit low-ambient (down to -18°C [0°F]) operation.

Power Disconnect Switch

A disconnect switch with a through-the-door handle, plus compressor protection fuses, is provided to disconnect main power.

Neoprene Isolators

Isolators provide isolation between the chiller and the structure to help eliminate vibration transmission. Neoprene isolators are more effective and recommended over spring isolators.

Flange adapter connection kit

Provides a kit that includes a set of two pipe stubs and Grooved pipe couplings.

Low Noise Version

The unit is equipped with low-speed fans and a compressor sound-attenuating enclosure. All the sound-emitting parts, like refrigerant lines are acoustically treated with sound-absorbent material.

Night Noise Setback

At night, on contact closure all the fans run at low speed, bringing the overall sound level further down. Only available on Low Noise, non High Ambient units.

Ground Fault Detection

Sensing ground current for improved chiller protection.

Pressure Gauges

A set of two pressure gauges per refrigerant circuit, one for low pressure and one for high pressure.

Flow Switch

For field installation on the chilled-water outlet connection.

Under/Over-voltage protection

Controls the variation of the power supply voltage. If the value exceeds the minimum or maximum voltage, the unit is shut down.

IP20 protection

Provides a protection against direct contacts inside the control panel. The current-carrying parts are shrouded in order to prevent accidental contact.

Evaporator connection (size 250-400)

2 tubes are added at the inlet and the outlet of the evaporator, so that the water Grooved pipe connection is brought outside of the unit.

Reduced length

(sizes 400HE and 400XE)

Total unit length is reduced which allows transport in a 45' high cube container. Performance is not affected. Night noise setback and low ambient options are not available.

Application Considerations

Figure 4 - Flow rate Out of Range

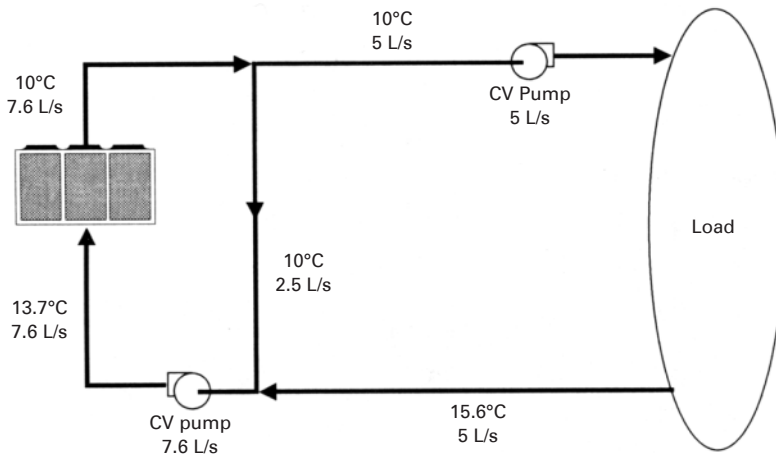

Ambient Limitations

Trane air-cooled Series R chillers are designed for year-round operation over a range of ambient temperatures. The air-cooled Model RTAC chiller will operate in ambient temperatures of 0 to 46°C [32 to 115°F]. Selecting the high-ambient option will allow the chiller to operate in ambient temperatures of 52°C [125°F], and selecting the low-ambient option will increase the operational capability of the water chiller to ambient temperatures as low as -18°C [0°F]. For operation outside of these ranges, contact the local sales office.

Water Flow Limits

The minimum water flow rates are given in Tables P1-18. Evaporator flow rates below the tabulated values will result in laminar flow and cause freeze-up problems, scaling, stratification, and poor control. The maximum evaporator water flow rate is also given in the general data section. Flow rates exceeding those listed may result in excessive tube erosion.

Flow Rates Out of Range

Many process cooling jobs require flow rates that cannot be met with the minimum and maximum published values within the Model RTAC evaporator. A simple piping change can alleviate this problem. For example: a plastic injection molding process requires 5.0 L/s [80 gpm] of 10°C [50°F] water and returns that water at 15.6°C [60°F]. The selected chiller can operate at these temperatures, but has a minimum flow rate of 7.6 L/s [120 gpm]. The following system can satisfy the process.

Important

Certain application constraints should be considered when sizing, selecting, and installing Trane air-cooled Series R chillers. Unit and system reliability is often dependent on properly and completely complying with these considerations. When the application varies from the guidelines presented, it should be reviewed with your local sales engineer.

Unit Sizing

Unit capacities are listed in the performance data section. Intentionally oversizing a unit to ensure adequate capacity is not recommended. Erratic system operation and excessive compressor cycling are often a direct result of an oversized chiller. In addition, an oversized unit is usually more expensive to purchase, install, and operate. If oversizing is desired, consider using two units.

Water Treatment

Dirt, scale, products of corrosion, and other foreign material will adversely affect heat transfer between the water and system components. Foreign matter in the chilled-water system can also increase pressure drop and, consequently, reduce water flow. Proper water treatment must be determined locally, depending on the type of system and local water characteristics. Neither salt nor brackish water is recommended for use in Trane air-cooled Series R chillers. Use of either will lead to a shortened chiller life. Trane encourages the employment of a reputable water-treatment specialist, familiar with local water conditions, to assist in this determination and in the establishment of a proper water-treatment program.

Effect of Altitude on Capacity

Air-cooled Series R chiller capacities given in the performance data tables are for use at sea level. At elevations substantially above sea level, the decreased air density will reduce condenser capacity and, therefore, unit capacity and efficiency.

Application Considerations

Flow Control

Trane requires the chilled water flow control in conjunction with the Air-Cooled Series R Chiller to be done by the chiller.

This will allow the chiller to protect itself in potentially harmful conditions.

Leaving-Water Temperature Limits

Trane air-cooled Series R chillers have three distinct leaving-water categories: standard, low temperature, and ice making. The standard leaving-solution temperature range is 4.4 to 15.6°C [40 to 60°F]. Low-temperature machines produce leaving-liquid temperatures less than 4.4°C [40°F]. Since liquid supply temperature set points less than 4.4°C [40°F] result in suction temperatures at or below the freezing point of water, a glycol solution is required for all low-temperature machines. Ice-making machines have a leaving-liquid temperature range of -6.7 to 15.6°C [20 to 60°F]. Ice-making controls include dual set point controls and safeties for ice making and standard cooling capabilities. Consult your local sales engineer for applications or selections involving low temperature or ice making machines. The maximum water temperature that can be circulated through an evaporator when the unit is not operating is 42°C [108°F].

Leaving-Water Temperature Out of Range

Many process cooling jobs require temperature ranges that cannot be met with the minimum and maximum published values for the RTAC evaporator. A simple piping change can alleviate this problem. For example: a laboratory load requires 7.6 L/s [120 gpm] of water entering the process at 29.4°C [85°F] and returning at 35°C [95°F]. The accuracy required is higher than the cooling tower can give. The selected chiller has adequate capacity, but has a maximum leaving-chilled-water temperature of 15.5°C [60°F]. In the example shown, both the chiller and process flow rates are equal. This is not necessary. For example, if the chiller had a higher flow rate, there would be more water bypassing and mixing with warm water.

Supply-Water Temperature Drop

The performance data for the Trane air-cooled Series R chiller is based on a chilled-water temperature drop of 6°C [10.8°F]. Chilled-water temperature drops from 3.3 to 10°C [6 to 18°F] may be used as long as minimum and maximum water temperature, and minimum and maximum flow rates, are not violated. Temperature drops outside this range are beyond the optimum range for control, and may adversely affect the microcomputer's ability to maintain an acceptable supply-water temperature range. Further, temperature drops of less than 3.3°C [6°F] may result in inadequate refrigerant superheat. Sufficient superheat is always a primary concern in any direct-expansion refrigerant system and is especially important in a package chiller where the evaporator is closely coupled to the compressor. When temperature drops are less than 3.3°C [6°F], an evaporator runaround loop may be required.

Figure 5 - Temperature Out of Range

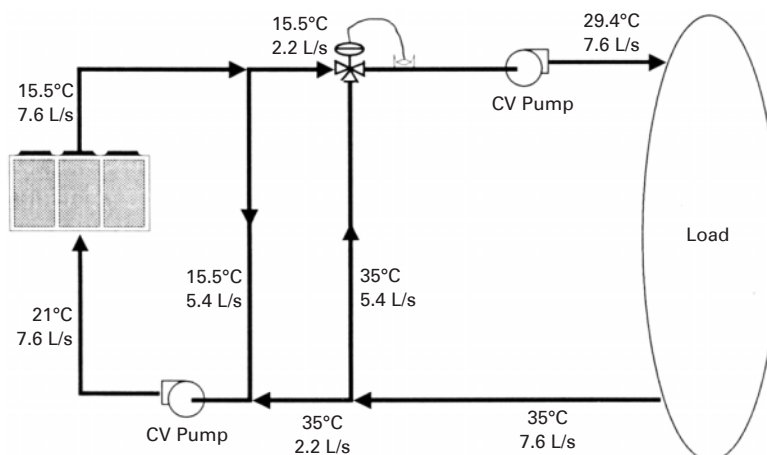

Application Considerations

Variable Flow in the Evaporator

An attractive chilled-water system option may be a variable primary flow (VPF) system. VPF systems present building owners with several cost-saving benefits that are directly related to the pumps. The most obvious cost savings result from eliminating the secondary distribution pump, which in turn avoids the expense incurred with the associated piping connections (material, labor), electrical service, and variable-frequency drive. Building owners often cite pump-related energy savings as the reason that prompted them to install a VPF system. With the help of a software analysis tool such as Trace 700, Trace System Analyser™, or DOE-2, you can determine whether the anticipated energy savings justify the use of variable primary flow in a particular application. It may also be easier to apply variable primary flow in an existing chilled-water plant. Unlike the “decoupled” design, the bypass can be positioned at various points in the chilled-water loop and an additional pump is unnecessary. The evaporator in the Model RTAC can withstand up to 50 percent water flow reduction as long as this flow is equal to or above the minimum flow-rate requirements. The microprocessor and capacity control algorithms are designed to handle a maximum of 10 percent change in water flow rate per minute in order to maintain $\pm 0.28^{\circ}\text{C}$ [0.5°F] leaving evaporator temperature control. For applications in which system energy savings is most important and tight temperature control is classified as $\pm 1.1^{\circ}\text{C}$ [2°F], up to 30 percent changes in flow per minute are possible.

Ice Storage Provides Reduced Electrical Demand

An ice-storage system uses a standard chiller to make ice at night, when utilities charge less for electricity. The ice supplements, or even replaces, mechanical cooling during the day, when utility rates are at their highest. This reduced need for cooling results in big utility cost savings.

Another advantage of ice storage is standby cooling capacity. If the chiller is unable to operate, one or two days of ice may still be available to provide cooling. In that period of time, the chiller can be repaired before building occupants feel any loss of comfort.

The Trane Model RTAC chiller is uniquely suited to low-temperature applications like ice storage because of the ambient relief experienced at night. This allows the Model RTAC chiller to produce ice efficiently, with less stress on the machine.

Simple and smart control strategies are another advantage the Model RTAC chiller offers for ice-storage applications. Trane Tracer™ building management systems can actually anticipate how much ice needs to be made at night, and operate the system accordingly. The controls are integrated right into the chiller. Two wires and preprogrammed software dramatically reduce field installation cost and complex programming.

Application Considerations

Short Water Loops

The proper location of the temperature control sensor is in the supply (outlet) water connection or pipe. This location allows the building to act as a buffer and assures a slowly-changing return-water temperature. If there is not a sufficient volume of water in the system to provide an adequate buffer, temperature control can be lost, resulting in erratic system operation and excessive compressor cycling. A short water loop has the same effect as attempting to control using the building return water. Typically, a two-minute water loop is sufficient to prevent a short water loop. Therefore, as a guideline, ensure that the volume of water in the evaporator loop equals or exceeds two times the evaporator flow rate per minute. For a rapidly changing load profile, the amount of volume should be increased. To prevent the effect of a short water loop, the following item should be given careful consideration: a storage tank or larger header pipe to increase the volume of water in the system and, therefore, reduce the rate of change of the return water temperature.

Applications Types

- Comfort cooling
- Industrial process cooling
- Ice or thermal storage
- Low-temperature process cooling.

Application Considerations

Typical Unit Installation

Outdoor HVAC equipment must be located to minimize noise and vibration transmission to the occupied spaces of the building structure it serves. If the equipment must be located in close proximity to a building, it could be placed next to an unoccupied space such as a storage room, mechanical room, etc. It is not recommended to locate the equipment near occupied, sound sensitive areas of the building or near windows. Locating the equipment away from structures will also prevent sound reflection, which can increase levels at property lines, or other sensitive points. When physically isolating the unit from structures, it is a good idea to not use rigid supports, and to eliminate any metal-to-metal or hard material contact, when possible. This includes replacing spring or metal weave isolation with elastomeric isolators. Figure 6 illustrates isolation recommendations for the RTAC.

Figure 6 - Unit isolation recommendations

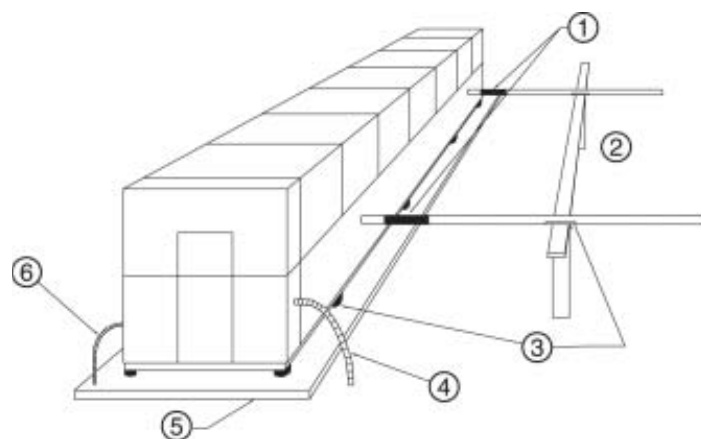

- 1 = Wall sleeves (flexible connection)
- 2 = Piping hanger
- 3 = Rubber pads
- 4 = Flexible electrical conduit
- 5 = Concrete solid foundation
- 6 = Auxiliary interlocks connection

Selection Procedure

Chiller selections and performance information can be obtained through the use of the Series R® Chiller selection program.

Performance

The computer selection program provides performance data for each chiller selection.

Dimensional Drawings

The dimensional drawings illustrate overall measurements of the unit. Also shown are the service clearances required to easily service the RTAC chiller. All catalog dimensional drawings are subject to change. Current submittal drawings should be referred to for detailed dimensional information. Contact the sales office for submittal information.

Electrical Data Tables

Compressor motor electrical data is shown in the data section for each compressor size. Rated load amperes (RLA), locked rotor Star-Delta amperes (LRAY), the power factor for standard voltages for all 50 Hz, 3-phase motors are shown. The RLA is based on the performance of the motor developing full rated horsepower. A voltage utilization range is tabulated for each voltage listed.

Evaporator and Condenser Pressure Drop

Pressure drop data is determined by the RTAC selection program.

General Data

SI Units

Table G-1 - General Data RTAC 140-200 Standard

Size		140	155	170	185	200
Cooling capacity (5) (6)	kW	491.9	537.3	585.4	648.0	714.5
Power input (7)	kW	170.1	187.8	206	224.7	244.2
Energy Efficiency Ratio (5) (6) (as Eurovent)	kW/kW	2.89	2.86	2.84	2.89	2.93
ESEER (as Eurovent)	kW/kW	3.68	3.68	3.61	3.43	3.67
IPLV (According to ARI conditions 44°F leaving water temperature, 95°C entering air temperature)	kW/kW	4.20	4.16	4.10	4.09	4.19
Compressor						
Quantity		2	2	2	2	2
Nominal Size (1)	tons	70/70	70/85	85/85	85/100	100/100
Evaporator						
Evaporator Model		H140	H155	H170	H185	H200
Water Storage	l	112	122	127	135	147
Minimum Flow	l/s	13	14	13	14	16
Maximum Flow	l/s	44	49	46	49	55
Number of water passes		2	2	2	2	2
Condenser						
Quantity of Coils		4	4	4	4	4
Coil Length	mm	3962/3962	4572/3962	4572/4572	5486/4572	5486/5486
Coil Height	mm	1067	1067	1067	1067	1067
Fin series	fins/ft	192	192	192	192	192
Number of Rows		3	3	3	3	3
Condenser Fans						
Quantity (1)		4/4	5/4	5/5	6/5	6/6
Diameter	mm	762	762	762	762	762
Total Air Flow	m ³ /s	35.45	39.19	42.94	47.23	51.53
Nominal RPM		915	915	915	915	915
Tip Speed	m/s	36.48	36.48	36.48	36.48	36.48
Motor kW	kW	1.57	1.57	1.57	1.57	1.57
Minimum Starting/Operating Ambient (2)						
Standard Unit	°C	0	0	0	0	0
Low-Ambient Unit	°C	-18	-18	-18	-18	-18
General Unit						
Refrigerant		HFC 134a	HFC 134a	HFC 134a	HFC 134a	HFC 134a
Number of Independent Refrigerant Circuits		2	2	2	2	2
% Minimum Load (3)		17	17	17	17	17
Operating Weight (4)	kg	4481	4659	4794	5366	5488
Shipping Weight (4)	kg	4525	4691	4834	5399	5508

Notes:

1. Data containing information on two circuits shown as follows: ckt1/ckt2
2. Minimum start-up/operation ambient based on a 2.22 m/s (5mph) wind across the condenser.
3. Percent minimum load is for total machine at 10°C (50°F) ambient and 7°C (44°F) leaving chilled water temperature, not each individual circuit.
4. With aluminium fins.
5. At Eurovent conditions, 7°C leaving water temperature and 35°C entering condenser air temperature.
6. Ratings based on sea level altitude and evaporator fouling factor of 0.044 m²K/kW
7. Unit kW input, including fans

General Data

SI Units

Table G-2 - General Data RTAC 120-200 High Efficiency

Size		120	130	140	155	170	185	200
Cooling capacity (5) (6)	kW	421.9	465.9	513.3	557.3	603.7	669.8	740.1
Power input (7)	kW	137.5	151.4	165.7	182.7	200.3	219.1	238.7
Energy Efficiency Ratio (5) (6) (as Eurovent)	kW/kW	3.07	3.08	3.1	3.05	3.02	3.06	3.1
ESEER (as Eurovent)	kW/kW	3.80	3.82	3.83	3.84	3.74	3.53	3.80
IPLV (According to ARI conditions 44°F leaving water temperature, 95°C entering air temperature)	kW/kW	4.31	4.31	4.36	4.32	4.24	4.23	4.32
Compressor								
Quantity		2	2	2	2	2	2	2
Nominal Size (1)	tons	60/60	60/70	70/70	70/85	85/85	85/100	100/100
Evaporator								
Evaporator Model		H140	H155	H170	H185	H200	H220	H240
Water Storage	l	112	122	127	135	147	146	159
Minimum Flow	l/s	13	14	13	14	16	14	16
Maximum Flow	l/s	44	49	46	49	55	49	55
Number of water passes		2	2	2	2	2	2	2
Condenser								
Quantity of Coils		4	4	4	4	4	4	4
Coil Length	mm	3962/3962	4572/3962	4572/4572	5486/4572	5486/5486	6400/2486	6400/6400
Coil Height	mm	1067	1067	1067	1067	1067	1067	1067
Fin series	fins/ft	192	192	192	192	192	192	192
Number of Rows		3	3	3	3	3	3	3
Condenser Fans								
Quantity (1)		4/4	5/4	5/5	6/5	6/6	7/6	7/7
Diameter	mm	762	762	762	762	762	762	762
Total Air Flow	m ³ /s	35.42	39.16	42.9	47.19	51.48	55.77	60.07
Nominal RPM		915	915	915	915	915	915	915
Tip Speed	m/s	36.48	36.48	36.48	36.48	36.48	36.48	36.48
Motor kW	kW	1.57	1.57	1.57	1.57	1.57	1.57	1.57
Minimum Starting/Operating Ambient (2)								
Standard Unit	°C	0	0	0	0	0	0	0
Low-Ambient Unit	°C	-18	-18	-18	-18	-18	-18	-18
General Unit								
Refrigerant		HFC 134a	HFC 134a	HFC 134a	HFC 134a	HFC 134a	HFC 134a	HFC 134a
Number of Independent Refrigerant Circuits		2	2	2	2	2	2	2
% Minimum Load (3)		17	17	17	17	17	17	17
Operating Weight (4)	kg	4461	4519	4529	5180	5431	6005	6117
Shipping Weight (4)	kg	4506	4550	4568	5212	5451	6026	6126

Notes:

1. Data containing information on two circuits shown as follows: ckt1/ckt2
2. Minimum start-up/operation ambient based on a 2.22 m/s (5mph) wind across the condenser.
3. Percent minimum load is for total machine at 10°C (50°F) ambient and 7°C (44°F) leaving chilled water temperature, not each individual circuit.
4. With aluminium fins.
5. At Eurovent conditions, 7°C leaving water temperature and 35°C entering condenser air temperature.
6. Ratings based on sea level altitude and evaporator fouling factor of 0.044 m²K/kW
7. Unit kW input, including fans

General Data

SI Units

Table G-3 - General Data RTAC 120-200 Extra Efficiency

Size		120	130	140	155	170	185	200
Cooling capacity (5) (6)	kW	426.8	474.7	520.7	566.4	632.8	679.6	747.1
Power input (7)	kW	135.1	149.7	164.8	179.8	198.4	215.7	236.4
Energy Efficiency Ratio (5) (6) (as Eurovent)	kW/kW	3.16	3.17	3.16	3.15	3.19	3.15	3.16
ESEER (as Eurovent)	kW/kW	3.92	3.86	3.92	3.84	4.07	3.95	3.90
IPLV (According to ARI conditions 44°F leaving water temperature, 95°C entering air temperature)	kW/kW	4.41	4.42	4.42	4.40	4.50	4.43	4.44
Compressor								
Quantity		2	2	2	2	2	2	2
Nominal Size (1)	tons	60/60	60/70	70/70	70/85	70/100	85/100	100/100
Evaporator								
Evaporator Model		H140	H155	H170	H185	H220	H220	H240
Water Storage	l	112	122	127	135	146	146	159
Minimum Flow	l/s	13	14	13	14	14	14	16
Maximum Flow	l/s	44	49	46	49	49	49	55
Number of water passes		2	2	2	2	2	2	2
Condenser								
Quantity of Coils		4	4	4	4	4	4	4
Coil Length	mm	4572/4572	4572/4572	4572/4572	5486/5486	5486/5486	6400/2486	6400/6400
Coil Height	mm	1067	1067	1067	1067	1067	1067	1067
Fin series	fins/ft	192	192/180	180	192/180	192/180	192	192
Number of Rows		3	3/4	4	3/4	3/4	3/4	4
Condenser Fans								
Quantity (1)		4/4	5/4	5/5	6/5	6/6	7/6	7/7
Diameter	mm	762	762	762	762	762	762	762
Total Air Flow	m ³ /s	37.21	42.22	41.58	50.66	54.83	59.11	58.22
Nominal RPM		915	915	915	915	915	915	915
Tip Speed	m/s	36.48	36.48	36.48	36.48	36.48	36.48	36.48
Motor kW	kW	1.57	1.57	1.57	1.57	1.57	1.57	1.57
Minimum Starting/Operating Ambient (2)								
Standard Unit	°C	0	0	0	0	0	0	0
Low-Ambient Unit	°C	-18	-18	-18	-18	-18	-18	-18
General Unit								
Refrigerant		HFC 134a	HFC 134a	HFC 134a	HFC 134a	HFC 134a	HFC 134a	HFC 134a
Number of Independent Refrigerant Circuits		2	2	2	2	2	2	2
% Minimum Load (3)		17	17	17	17	17	17	17
Operating Weight (4)	kg	4775	4712	4613	5351	5842	6307	6497
Shipping Weight (4)	kg	4677	4969	4969	4506	4506	4604	5069

Notes:

1. Data containing information on two circuits shown as follows: ckt1/ckt2
2. Minimum start-up/operation ambient based on a 2.22 m/s (5mph) wind across the condenser.
3. Percent minimum load is for total machine at 10°C (50°F) ambient and 7°C (44°F) leaving chilled water temperature, not each individual circuit.
4. With aluminium fins.
5. At Eurovent conditions, 7°C leaving water temperature and 35°C entering condenser air temperature.
6. Ratings based on sea level altitude and evaporator fouling factor of 0.044 m²K/kW
7. Unit kW input, including fans

General Data

SI Units

Table G-4 - General Data RTAC 140-200 Low Noise Standard

Size		140	155	170	185	200
Cooling capacity (5) (6)	kW	465.9	508.8	554.5	614.3	677.9
Power input (7)	kW	178.2	196.1	214.9	234.3	254.6
Energy Efficiency Ratio (5) (6) (as Eurovent)	kW/kW	2.61	2.6	2.58	2.62	2.66
ESEER (as Eurovent)	kW/kW	3.64	3.53	3.51	3.49	3.56
IPLV (According to ARI conditions 44°F leaving water temperature, 95°C entering air temperature)	kW/kW	4.09	4.04	4.03	3.99	4.11
Compressor						
Quantity		2	2	2	2	2
Nominal Size (1)	tons	70/70	70/85	85/85	85/100	100/100
Evaporator						
Evaporator Model		H140	H155	H170	H185	H200
Water Storage	l	112	122	127	135	147
Minimum Flow	l/s	13	14	13	14	16
Maximum Flow	l/s	44	49	46	49	55
Number of water passes		2	2	2	2	2
Condenser						
Quantity of Coils		4	4	4	4	4
Coil Length	mm	3962/3962	4572/3962	4572/4572	5486/4572	5486/5486
Coil Height	mm	1067	1067	1067	1067	1067
Fin series	fins/ft	192	192	192	192	192
Number of Rows		3	3	3	3	3
Condenser Fans						
Quantity (1)		4/4	5/4	5/5	6/5	6/6
Diameter	mm	762	762	762	762	762
Total Air Flow	m ³ /s	26.49	29.17	31.84	35.02	38.21
Nominal RPM		680	680	680	680	680
Tip Speed	m/s	27.5	27.5	27.5	27.5	27.5
Motor kW	kW	0.75	0.75	0.75	0.75	0.75
Minimum Starting/Operating Ambient (2)						
Standard Unit	°C	0	0	0	0	0
Low-Ambient Unit	°C	-18	-18	-18	-18	-18
General Unit						
Refrigerant		HFC 134a	HFC 134a	HFC 134a	HFC 134a	HFC 134a
Number of Independent Refrigerant Circuits		2	2	2	2	2
% Minimum Load (3)		17	17	17	17	17
Operating Weight (4)	kg	4481	4659	4794	5366	5488
Shipping Weight (4)	kg	4525	4691	4834	5399	5508

Notes:

1. Data containing information on two circuits shown as follows: ckt1/ckt2
2. Minimum start-up/operation ambient based on a 2.22 m/s (5mph) wind across the condenser.
3. Percent minimum load is for total machine at 10°C (50°F) ambient and 7°C (44°F) leaving chilled water temperature, not each individual circuit.
4. With aluminium fins.
5. At Eurovent conditions, 7°C leaving water temperature and 35°C entering condenser air temperature.
6. Ratings based on sea level altitude and evaporator fouling factor of 0.044 m²K/kW
7. Unit kW input, including fans

General Data

SI Units

Table G-5 - General Data RTAC 120-200 High Efficiency Low Noise

Size		120	130	140	155	170	185	200
Cooling capacity (5) (6)	kW	405.0	447.6	493.3	535.5	580.1	643.8	711.3
Power input (7)	kW	141	155.1	169.8	186.8	204.3	223.8	244.2
Energy Efficiency Ratio (5) (6) (as Eurovent)	kW/kW	2.88	2.89	2.91	2.87	2.84	2.88	2.91
ESEER (as Eurovent)	kW/kW	3.78	3.78	3.83	3.82	3.76	3.75	3.80
IPLV (According to ARI conditions 44°F leaving water temperature, 95°C entering air temperature)	kW/kW	4.32	4.31	4.39	4.33	4.28	4.25	4.35
Compressor								
Quantity		2	2	2	2	2	2	2
Nominal Size (1)	tons	60/60	60/70	70/70	70/85	85/85	85/100	100/100
Evaporator								
Evaporator Model		H140	H155	H170	H185	H200	H220	H240
Water Storage	l	112	122	127	135	147	146	159
Minimum Flow	l/s	13	14	13	14	16	14	16
Maximum Flow	l/s	44	49	46	49	55	49	55
Number of water passes		2	2	2	2	2	2	2
Condenser								
Quantity of Coils		4	4	4	4	4	4	4
Coil Length	mm	3962/3962	4572/3962	4572/4572	5486/4572	5486/5486	6400/2486	6400/6400
Coil Height	mm	1067	1067	1067	1067	1067	1067	1067
Fin series	fins/ft	192	192	192	192	192	192	192
Number of Rows		3	3	3	3	3	3	3
Condenser Fans								
Quantity (1)		4/4	5/4	5/5	6/5	6/6	7/6	7/7
Diameter	mm	762	762	762	762	762	762	762
Total Air Flow	m ³ /s	26.46	29.13	31.8	34.97	38.15	41.34	44.53
Nominal RPM		680	680	680	680	680	680	680
Tip Speed	m/s	27.5	27.5	27.5	27.5	27.5	27.5	27.5
Motor kW	kW	0.75	0.75	0.75	0.75	0.75	0.75	0.75
Minimum Starting/Operating Ambient (2)								
Standard Unit	°C	0	0	0	0	0	0	0
Low-Ambient Unit	°C	-18	-18	-18	-18	-18	-18	-18
General Unit								
Refrigerant		HFC 134a	HFC 134a	HFC 134a	HFC 134a	HFC 134a	HFC 134a	HFC 134a
Number of Independent Refrigerant Circuits		2	2	2	2	2	2	2
% Minimum Load (3)		17	17	17	17	17	17	17
Operating Weight (4)	kg	4461	4519	4529	5180	5431	6005	6117
Shipping Weight (4)	kg	4506	4550	4568	5212	5451	6026	6126

Notes:

1. Data containing information on two circuits shown as follows: ckt1/ckt2
2. Minimum start-up/operation ambient based on a 2.22 m/s (5mph) wind across the condenser.
3. Percent minimum load is for total machine at 10°C (50°F) ambient and 7°C (44°F) leaving chilled water temperature, not each individual circuit.
4. With aluminium fins.
5. At Eurovent conditions, 7°C leaving water temperature and 35°C entering condenser air temperature.
6. Ratings based on sea level altitude and evaporator fouling factor of 0.044 m²K/kW
7. Unit kW input, including fans

General Data

SI Units

Table G-6 - General Data RTAC 120-200 Extra Efficiency Low Noise

Size		120	130	140	155	170	185	200
Cooling capacity (5) (6)	kW	412.7	459.2	501.7	548.8	611.8	657.1	718.7
Power input (7)	kW	135.1	149.7	164.8	179.8	198.4	215.7	236.4
Energy Efficiency Ratio (5) (6) (as Eurovent)	kW/kW	3.01	3.03	2.96	3.01	3.04	3	2.96
ESEER (as Eurovent)	kW/kW	3.96	3.89	3.92	3.99	4.15	4.02	3.88
IPLV (According to ARI conditions 44°F leaving water temperature, 95°C entering air temperature)	kW/kW	4.48	4.51	4.45	4.54	4.62	4.52	4.41
Compressor								
Quantity		2	2	2	2	2	2	2
Nominal Size (1)	tons	60/60	60/70	70/70	70/85	70/100	85/100	100/100
Evaporator								
Evaporator Model		H140	H155	H170	H185	H220	H220	H240
Water Storage	l	112	122	127	135	146	146	159
Minimum Flow	l/s	13	14	13	14	14	14	16
Maximum Flow	l/s	44	49	46	49	49	49	55
Number of water passes		2	2	2	2	2	2	2
Condenser								
Quantity of Coils		4	4	4	4	4	4	4
Coil Length	mm	4572/4572	4572/4572	4572/4572	5486/5486	5486/5486	6400/2486	6400/6400
Coil Height	mm	1067	1067	1067	1067	1067	1067	1067
Fin series	fins/ft	192	192/180	180	192/180	192/180	192	192
Number of Rows		3	3/4	4	3/4	3/4	3/4	4
Condenser Fans								
Quantity (1)		4/4	5/4	5/5	6/5	6/6	7/6	7/7
Diameter	mm	762	762	762	762	762	762	762
Total Air Flow	m ³ /s	28.13	31.15	30.54	37.37	40.43	43.61	42.76
Nominal RPM		680	680	680	680	680	680	680
Tip Speed	m/s	27.5	27.5	27.5	27.5	27.5	27.5	27.5
Motor kW	kW	0.75	0.75	0.75	0.75	0.75	0.75	0.75
Minimum Starting/Operating Ambient (2)								
Standard Unit	°C	0	0	0	0	0	0	0
Low-Ambient Unit	°C	-18	-18	-18	-18	-18	-18	-18
General Unit								
Refrigerant		HFC 134a	HFC 134a	HFC 134a	HFC 134a	HFC 134a	HFC 134a	HFC 134a
Number of Independent Refrigerant Circuits		2	2	2	2	2	2	2
% Minimum Load (3)		17	17	17	17	17	17	17
Operating Weight (4)	kg	4775	4712	4613	5351	5842	6307	6497
Shipping Weight (4)	kg	4677	4969	4969	4506	4506	4604	5069

Notes:

1. Data containing information on two circuits shown as follows: ckt1/ckt2
2. Minimum start-up/operation ambient based on a 2.22 m/s (5mph) wind across the condenser.
3. Percent minimum load is for total machine at 10°C (50°F) ambient and 7°C (44°F) leaving chilled water temperature, not each individual circuit.
4. With aluminium fins.
5. At Eurovent conditions, 7°C leaving water temperature and 35°C entering condenser air temperature.
6. Ratings based on sea level altitude and evaporator fouling factor of 0.044 m²/K/kW
7. Unit kW input, including fans

General Data

SI Units

Table G-7 - General Data RTAC 230-400 Standard

Size		230	240	250	275	300	350	375	400
Cooling capacity (5) (6)	kW	769.7	857.9	850.9	947.2	1077.3	1191.6	1322.4	1451.4
Power input (7)	kW	263	293.6	293.4	330.5	370.2	418.9	458.8	498.4
Energy Efficiency Ratio (5) (6) (as Eurovent)	kW/kW	2.93	2.92	2.9	2.87	2.91	2.85	2.88	2.91
ESEER (as Eurovent)	kW/kW	3.94	4.17	3.82	3.86	3.94	4.10	4.14	4.18
IPLV (According to ARI conditions 44°F leaving water temperature, 95°C entering air temperature)	kW/kW	4.31	4.35	4.05	4.05	3.97	4.47	4.50	4.54
Compressor									
Quantity		3	3	3	3	3	4	4	4
Nominal Size (1)	tons	60-60/100	70-70/100	70-70/100	85-85/100	100-100/100	85-85/85-85	100-100/85-85	100-100/100-100
Evaporator									
Evaporator Model		EH270	EH270	EH250	EH270	EH301	EH340	EH370	EH401
Water Storage	l	223	223	198	223	239	264	280	294
Minimum Flow	l/s	20	20	17	20	22	22	24	26
Maximum Flow	l/s	71	71	60	71	77	80	87	92
Number of water passes		2	2	2	2	2	2	2	2
Condenser									
Quantity of Coils		2/2	2/2	4/4	4/4	4/4	4/4	4/4	4/4
Coil Length	mm	6401/6401	6401/6401	3962/2743	4572/2743	5486/2743	4572/4572	5486/4572	5486/5486
Coil Height	mm	1067	1067	1067	1067	1067	1067	1067	1067
Fin series	fins/ft	192	180	192	192	192	192	192	192
Number of Rows		3	4	3	3	3	3	3	3
Condenser Fans									
Quantity (1)		7/7	7/7	8/6	10/6	12/6	10/10	12/10	12/12
Diameter	mm	762	762	762	762	762	762	762	762
Total Air Flow	m ³ /s	60.09	58.27	61.21	68.7	77.29	85.88	94.47	103.06
Nominal RPM		915	915	915	915	915	915	915	915
Tip Speed	m/s	36.48	36.48	36.48	36.48	36.48	36.48	36.48	36.49
Motor kW	kW	1.57	1.57	1.57	1.57	1.57	1.57	1.57	1.57
Minimum Starting/Operating Ambient (2)									
Standard Unit	°C	0	0	0	0	0	0	0	0
Low-Ambient Unit	°C	-18	-18	-18	-18	-18	-18	-18	-18
General Unit									
Refrigerant		HFC 134a	HFC 134a	HFC 134a	HFC 134a	HFC 134a	HFC 134a	HFC 134a	HFC 134a
Number of Independent Refrigerant Circuits		2	2	2	2	2	2	2	2
% Minimum Load (3)		13	13	13	13	13	10	10	10
Operating Weight (4)	kg	8040	8040	7892	8664	9375	10684	11330	11929
Shipping Weight (4)	kg	7660	7660	7694	8441	9136	10420	11050	11635

Notes:

1. Data containing information on two circuits shown as follows: ckt1/ckt2
2. Minimum start-up/operation ambient based on a 2.22 m/s (5mph) wind across the condenser.
3. Percent minimum load is for total machine at 10°C (50°F) ambient and 7°C (44°F) leaving chilled water temperature, not each individual circuit.
4. With aluminium fins.
5. At Eurovent conditions, 7°C leaving water temperature and 35°C entering condenser air temperature.
6. Ratings based on sea level altitude and evaporator fouling factor of 0.044 m²K/kW
7. Unit kW input, including fans

General Data

SI Units

Table G-8 - General Data RTAC 250-400 High Efficiency

Size		250	275	300	350	375	400
Cooling capacity (5) (6)	kW	876.9	978.5	1111.8	1227.8	1363.9	1501.3
Power input (7)	kW	289.8	321	360.2	407.2	446.9	486.9
Energy Efficiency Ratio (5) (6) (as Eurovent)	kW/kW	3.03	3.05	3.09	3.02	3.05	3.09
ESEER (as Eurovent)	kW/kW	3.84	4.00	4.08	4.09	4.13	4.18
IPLV (According to ARI conditions 44°F leaving water temperature, 95°C entering air temperature)	kW/kW	4.10	4.35	4.45	4.44	4.47	4.54
Compressor							
Quantity		3	3	3	4	4	4
Nominal Size (1)	tons	70-70/100	85-85/100	100-100/100	85-85/85-85	100-100/85-85	100-100/100-100
Evaporator							
Evaporator Model		EH300	EH320	EH321	EH400	EH440	EH480
Water Storage	l	239	258	258	294	304	325
Minimum Flow	l/s	22	24	24	26	27	29
Maximum Flow	l/s	77	86	86	92	97	105
Number of water passes		2	2	2	2	2	2
Condenser							
Quantity of Coils		4/4	4/4	4/4	4/4	4/4	4/4
Coil Length	mm	4572/2743	5486/3658	6401/3658	5486/5486	6401/5486	6401/6401
Coil Height	mm	1067	1067	1067	1067	1067	1067
Fin series	fins/ft	192	192	192	192	192	192
Number of Rows		3	3	3	3	3	3
Condenser Fans							
Quantity (1)		10/6	12/6	14/6	12/12	14/12	14/14
Diameter	mm	762	762	762	762	762	762
Total Air Flow	m ³ /s	68.66	79.95	88.54	102.96	111.55	120.15
Nominal RPM		915	915	915	915	915	915
Tip Speed	m/s	36.48	36.48	36.48	36.48	36.48	36.48
Motor kW	kW	1.57	1.57	1.57	1.57	1.57	1.57
Minimum Starting/Operating Ambient (2)							
Standard Unit	°C	0	0	0	0	0	0
Low-Ambient Unit	°C	-18	-18	-18	-18	-18	-18
General Unit							
Refrigerant		HFC 134a	HFC 134a	HFC 134a	HFC 134a	HFC 134a	HFC 134a
Number of Independent Refrigerant Circuits		2	2	2	2	2	2
% Minimum Load (3)		13	13	13	10	10	10
Operating Weight (4)	kg	8359	9718	10258	11973	12507	13185
Shipping Weight (4)	kg	8120	9460	10000	11679	12204	12860

Notes:

1. Data containing information on two circuits shown as follows: ckt1/ckt2
2. Minimum start-up/operation ambient based on a 2.22 m/s (5mph) wind across the condenser.
3. Percent minimum load is for total machine at 10°C (50°F) ambient and 7°C (44°F) leaving chilled water temperature, not each individual circuit.
4. With aluminium fins.
5. At Eurovent conditions, 7°C leaving water temperature and 35°C entering condenser air temperature.
6. Ratings based on sea level altitude and evaporator fouling factor of 0.044 m²K/kW
7. Unit kW input, including fans

General Data

SI Units

Table G-9 - General Data RTAC 255-400 Extra Efficiency

Size		255	275	300	355	375	400
Cooling capacity (5) (6)	kW	898.7	998.2	1128.3	1290.0	1388.1	1516.8
Power input (7)	kW	283.5	318.9	355.9	408.2	444.9	481.5
Energy Efficiency Ratio (5) (6) (as Eurovent)	kW/kW	3.17	3.13	3.17	3.16	3.12	3.15
ESEER (as Eurovent)	kW/kW	3.95	4.01	4.13	4.15	4.22	4.23
IPLV (According to ARI conditions 44°F leaving water temperature, 95°C entering air temperature)	kW/kW	4.43	4.43	4.5	4.52	4.57	4.56
Compressor							
Quantity		3	3	3	4	4	4
Nominal Size (1)	tons	70-70/100	85-85/100	100-100/100	70-70/100-100	100-100/85-85	100-100/100-100
Evaporator							
Evaporator Model		EH300	EH320	EH321	EH440	EH480	EH480
Water Storage	l	239	258	258	304	325	325
Minimum Flow	l/s	22	24	24	27	29	29
Maximum Flow	l/s	77	86	86	97	105	105
Number of water passes		2	2	2	2	2	2
Condenser							
Quantity of Coils		4/4	4/4	4/4	4/4	4/4	4/4
Coil Length	mm	4572/2743	5486/3658	6401/3658	4572/6401	6401/5486	6401/6401
Coil Height	mm	1067	1067	1067	1067	1067	1067
Fin series	fins/ft	180	180	180	180	180	180
Number of Rows		4	4	4	4	4	4
Condenser Fans							
Quantity (1)		10/6	12/6	14/6	12/12	14/12	14/14
Diameter	mm	762	762	762	762	762	762
Total Air Flow	m ³ /s	69.41	83.14	91.46	99.8	108.2	116.4
Nominal RPM		915	915	915	915	915	915
Tip Speed	m/s	36.48	36.48	36.48	36.48	36.48	36.48
Motor kW	kW	1.57	1.57	1.57	1.57	1.57	1.57
Minimum Starting/Operating Ambient (2)							
Standard Unit	°C	0	0	0	0	0	0
Low-Ambient Unit	°C	-18	-18	-18	-18	-18	-18
General Unit							
Refrigerant		HFC 134a	HFC 134a	HFC 134a	HFC 134a	HFC 134a	HFC 134a
Number of Independent Refrigerant Circuits		2	2	2	2	2	2
% Minimum Load (3)		13	13	13	10	10	10
Operating Weight (4)	kg	9484	10180	10795	12217	13092	13784
Shipping Weight (4)	kg	9245	9922	10537	11913	12766	13459

Notes:

1. Data containing information on two circuits shown as follows: ckt1/ckt2
2. Minimum start-up/operation ambient based on a 2.22 m/s (5mph) wind across the condenser.
3. Percent minimum load is for total machine at 10°C (50°F) ambient and 7°C (44°F) leaving chilled water temperature, not each individual circuit.
4. With aluminium fins.
5. At Eurovent conditions, 7°C leaving water temperature and 35°C entering condenser air temperature.
6. Ratings based on sea level altitude and evaporator fouling factor of 0.044 m²K/kW
7. Unit kW input, including fans

General Data

SI Units

Table G-10 - General Data RTAC 230-400 Low Noise Standard

Size		230	240	250	275	300	350	375	400
Cooling capacity (5) (6)	kW	728.9	798.1	806.6	897.6	1021.8	1127.2	1252.4	1375.8
Power input (7)	kW	271.9	309.6	306.7	344.6	385.7	437	478.5	519.6
Energy Efficiency Ratio (5) (6) (as Eurovent)	kW/kW	2.68	2.58	2.63	2.61	2.65	2.58	2.62	2.65
ESEER (as Eurovent)	kW/kW	4.06	4.13	3.63	3.89	4.02	4.34	4.37	4.44
IPLV (According to ARI conditions 44°F leaving water temperature, 95°C entering air temperature)	kW/kW	4.47	4.51	4.13	4.17	4.06	4.72	4.77	4.85
Compressor									
Quantity		3	3	3	3	3	4	4	4
Nominal Size (1)	tons	60-60/100	70-70/100	70-70/100	85-85/100	100-100/100	85-85/85-85	100-100/85-85	100-100/100-100
Evaporator									
Evaporator Model		EH270	EH270	EH250	EH270	EH301	EH340	EH370	EH401
Water Storage	l	223	223	198	223	239	264	280	294
Minimum Flow	l/s	20	20	17	20	22	22	24	26
Maximum Flow	l/s	71	71	60	71	77	80	87	92
Number of water passes		2	2	2	2	2	2	2	2
Condenser									
Quantity of Coils		2/2	2/2	4/4	4/4	4/4	4/4	4/4	4/4
Coil Length	mm	6401/6401	6401/6401	3962/2743	4572/2743	5486/2743	4572/4572	5486/4572	5486/5486
Coil Height	mm	1067	1067	1067	1067	1067	1067	1067	1067
Fin series	fins/ft	192	180	192	192	192	192	192	192
Number of Rows		3	4	3	3	3	3	3	3
Condenser Fans									
Quantity (1)		7/7	7/7	8/6	10/6	12/6	10/10	12/10	12/12
Diameter	mm	762	762	762	762	762	762	762	762
Total Air Flow	m ³ /s	44.55	42.82	45.6	50.95	57.32	63.69	70.06	76.43
Nominal RPM		680	680	680	680	680	680	680	680
Tip Speed	m/s	27.5	27.5	27.5	27.5	27.5	27.5	27.5	27.5
Motor kW	kW	0.75	0.75	0.75	0.75	0.75	0.75	0.75	0.75
Minimum Starting/Operating Ambient (2)									
Standard Unit	°C	0	0	0	0	0	0	0	0
Low-Ambient Unit	°C	-18	-18	-18	-18	-18	-18	-18	-18
General Unit									
Refrigerant		HFC 134a	HFC 134a	HFC 134a	HFC 134a	HFC 134a	HFC 134a	HFC 134a	HFC 134a
Number of Independent Refrigerant Circuits		2	2	2	2	2	2	2	2
% Minimum Load (3)		13	13	13	13	13	10	10	10
Operating Weight (4)	kg	8040	8040	7958	8745	9473	10779	11436	12051
Shipping Weight (4)	kg	7660	7760	7820	8581	9296	10617	11279	11881

Notes:

1. Data containing information on two circuits shown as follows: ckt1/ckt2
2. Minimum start-up/operation ambient based on a 2.22 m/s (5mph) wind across the condenser.
3. Percent minimum load is for total machine at 10°C (50°F) ambient and 7°C (44°F) leaving chilled water temperature, not each individual circuit.
4. With aluminium fins.
5. At Eurovent conditions, 7°C leaving water temperature and 35°C entering condenser air temperature.
6. Ratings based on sea level altitude and evaporator fouling factor of 0.044 m²K/kW
7. Unit kW input, including fans

General Data

SI Units

Table G-11 - General Data RTAC 250-400 High Efficiency Low Noise

Size		250	275	300	350	375	400
Cooling capacity (5) (6)	kW	838.6	940.9	1068.9	1179.3	1310.1	1442.3
Power input (7)	kW	299	328.3	368.9	415.6	456.6	498.1
Energy Efficiency Ratio (5) (6) (as Eurovent)	kW/kW	2.81	2.87	2.9	2.84	2.87	2.9
ESEER (as Eurovent)	kW/kW	3.89	4.12	4.20	4.44	4.46	4.53
IPLV (According to ARI conditions 44°F leaving water temperature, 95°C entering air temperature)	kW/kW	4.13	4.36	4.24	4.82	4.86	4.94
Compressor							
Quantity		3	3	3	4	4	4
Nominal Size (1)	tons	70-70/100	85-85/100	100-100/100	85-85/85-85	100-100/85-85	100-100/100-100
Evaporator							
Evaporator Model		EH300	EH320	EH321	EH400	EH440	EH480
Water Storage	l	239	258	258	294	304	325
Minimum Flow	l/s	22	24	24	26	27	29
Maximum Flow	l/s	77	86	86	92	97	105
Number of water passes		2	2	2	2	2	2
Condenser							
Quantity of Coils		4/4	4/4	4/4	4/4	4/4	4/4
Coil Length	mm	4572/2743	5486/3658	6401/3658	5486/5486	6401/5486	6401/6401
Coil Height	mm	1067	1067	1067	1067	1067	1067
Fin series	fins/ft	192	192	192	192	192	192
Number of Rows		3	3	3	3	3	3
Condenser Fans							
Quantity (1)		10/6	12/6	14/6	12/12	14/12	14/14
Diameter	mm	762	762	762	762	762	762
Total Air Flow	m ³ /s	50.91	59.78	66.15	76.32	82.69	89.07
Nominal RPM		680	680	680	680	680	680
Tip Speed	m/s	27.5	27.5	27.5	27.5	27.5	27.5
Motor kW	kW	0.75	0.75	0.75	0.75	0.75	0.75
Minimum Starting/Operating Ambient (2)							
Standard Unit	°C	0	0	0	0	0	0
Low-Ambient Unit	°C	-18	-18	-18	-18	-18	-18
General Unit							
Refrigerant		HFC 134a	HFC 134a	HFC 134a	HFC 134a	HFC 134a	HFC 134a
Number of Independent Refrigerant Circuits		2	2	2	2	2	2
% Minimum Load (3)		13	13	13	10	10	10
Operating Weight (4)	kg	8440	9818	10337	12097	12627	13325
Shipping Weight (4)	kg	7820	9623	10141	11924	12434	13109

Notes:

1. Data containing information on two circuits shown as follows: ckt1/ckt2
2. Minimum start-up/operation ambient based on a 2.22 m/s (5mph) wind across the condenser.
3. Percent minimum load is for total machine at 10°C (50°F) ambient and 7°C (44°F) leaving chilled water temperature, not each individual circuit.
4. With aluminium fins.
5. At Eurovent conditions, 7°C leaving water temperature and 35°C entering condenser air temperature.
6. Ratings based on sea level altitude and evaporator fouling factor or 0.044 m²K/kW
7. Unit kW input, including fans

General Data

SI Units

Table G-12 - General Data RTAC 255-400 Extra Efficiency Low Noise

Size		255	275	300	355	375	400
Cooling capacity (5) (6)	kW	867.4	966.5	1090.3	1239.7	1334.3	1456.7
Power input (7)	kW	292.1	324.3	363.4	418.8	455.4	495.5
Energy Efficiency Ratio (5) (6) (as Eurovent)	kW/kW	2.97	2.98	3.00	2.96	2.93	2.94
ESEER (as Eurovent)	kW/kW	4.03	4.38	4.42	4.48	4.6	4.57
IPLV (According to ARI conditions 44°F leaving water temperature, 95°C entering air temperature)	kW/kW	4.50	4.57	4.44	4.7	4.98	4.95
Compressor							
Quantity		3	3	3	4	4	4
Nominal Size (1)	tons	70-70/100	85-85/100	100-100/100	70-70/100-100	100-100/85-85	100-100/100-100
Evaporator							
Evaporator Model		EH300	EH320	EH321	EH440	EH480	EH480
Water Storage	l	239	258	258	304	325	325
Minimum Flow	l/s	22	24	24	27	29	29
Maximum Flow	l/s	77	86	86	97	105	105
Number of water passes		2	2	2	2	2	2
Condenser							
Quantity of Coils		4/4	4/4	4/4	4/4	4/4	4/4
Coil Length	mm	4572/2743	5486/3658	6401/3658	4572/6401	6401/5486	6401/6401
Coil Height	mm	1067	1067	1067	1067	1067	1067
Fin series	fins/ft	180	180	180	180	180	180
Number of Rows		4	4	4	4	4	4
Condenser Fans							
Quantity (1)		10/6	12/6	14/6	12/12	14/12	14/14
Diameter	mm	762	762	762	762	762	762
Total Air Flow	m ³ /s	51.54	61.05	67.17	73.31	79.41	85.53
Nominal RPM		680	680	680	680	680	680
Tip Speed	m/s	27.5	27.5	27.5	27.5	27.5	27.5
Motor kW	kW	0.75	0.75	0.75	0.75	0.75	0.75
Minimum Starting/Operating Ambient (2)							
Standard Unit	°C	0	0	0	0	0	0
Low-Ambient Unit	°C	-18	-18	-18	-18	-18	-18
General Unit							
Refrigerant		HFC 134a	HFC 134a	HFC 134a	HFC 134a	HFC 134a	HFC 134a
Number of Independent Refrigerant Circuits		2	2	2	2	2	2
% Minimum Load (3)		13	13	13	10	10	10
Operating Weight (4)	kg	9540	10291	10964	11704	13233	14083
Shipping Weight (4)	kg	9436	10168	10843	11713	13196	14029

Notes:

1. Data containing information on two circuits shown as follows: ckt1/ckt2
2. Minimum start-up/operation ambient based on a 2.22 m/s (5mph) wind across the condenser.
3. Percent minimum load is for total machine at 10°C (50°F) ambient and 7°C (44°F) leaving chilled water temperature, not each individual circuit.
4. With aluminium fins.
5. At Eurovent conditions, 7°C leaving water temperature and 35°C entering condenser air temperature.
6. Ratings based on sea level altitude and evaporator fouling factor of 0.044 m²/K/kW
7. Unit kW input, including fans

General Data

English Units

Table G-13 - General Data RTAC 140-200 Standard

Size		140	155	170	185	200
Cooling capacity (5) (6)	tons	139.9	152.8	166.5	184.3	203.2
Power input (7)	kW	170.1	187.8	206	224.7	244.2
Energy Efficiency Ratio (5) (6) (as Eurovent)	MBH/kW	9.86	9.76	9.69	9.86	10.00
ESEER (as Eurovent)	MBH/kW	12.56	12.56	12.32	11.70	12.52
IPLV (According to ARI conditions 44°F leaving water temperature, 95°C entering air temperature)	MBH/kW	14.33	14.19	13.99	13.96	14.30
Compressor						
Quantity		2	2	2	2	2
Nominal Size (1)	tons	70/70	70/85	85/85	85/100	100/100
Evaporator						
Evaporator Model		H140	H155	H170	H185	H200
Water Storage	gal.	30	32	34	36	39
Minimum Flow	gpm	206	222	206	222	254
Maximum Flow	gpm	697	777	729	777	872
Number of water passes		2	2	2	2	2
Condenser						
Quantity of Coils		4	4	4	4	4
Coil Length	ft	13/13	15/13	15/15	18/15	18/18
Coil Height	ft	3.5	3.5	3.5	3.5	3.5
Fin series	fins/ft	192	192	192	192	192
Number of Rows		3	3	3	3	3
Condenser Fans						
Quantity (1)		4/4	5/4	5/5	6/5	6/6
Diameter	in.	30	30	30	30	30
Total Air Flow	cfm	75114	83039	90985	100075	109186
Nominal RPM		915	915	915	915	915
Tip Speed	ft/s	120	120	120	120	120
Motor kW	kW	1.57	1.57	1.57	1.57	1.57
Minimum Starting/Operating Ambient (2)						
Standard Unit	°F	32	32	32	32	32
Low-Ambient Unit	°F	0	0	0	0	0
General Unit						
Refrigerant		HFC 134a	HFC 134a	HFC 134a	HFC 134a	HFC 134a
Number of Independent Refrigerant Circuits		2	2	2	2	2
% Minimum Load (3)		17	17	17	17	17
Operating Weight (4)	lb	9858	10250	10547	11805	12074
Shipping Weight (4)	lb	9955	10320	10635	11878	12118

Notes:

1. Data containing information on two circuits shown as follows: ckt1/ckt2
2. Minimum start-up/operation ambient based on a 2.22 m/s (5mph) wind across the condenser.
3. Percent minimum load is for total machine at 10°C (50°F) ambient and 7°C (44°F) leaving chilled water temperature, not each individual circuit.
4. With aluminium fins.
5. At Eurovent conditions, 7°C leaving water temperature and 35°C entering condenser air temperature.
6. Ratings based on sea level altitude and evaporator fouling factor or 0.044 m²K/kW
7. Unit kW input, including fans

General Data

English Units

Table G-14 - General Data RTAC 120-200 High Efficiency

Size		120	130	140	155	170	185	200
Cooling capacity (5) (6)	tons	120.0	132.5	146.0	158.5	171.7	190.5	210.5
Power input (7)	kW	137.5	151.4	165.7	182.7	200.3	219.1	238.7
Energy Efficiency Ratio (5) (6) (as Eurovent)	MBH/kW	10.47	10.51	10.58	10.41	10.30	10.44	10.58
ESEER (as Eurovent)	MBH/kW	12.97	13.03	13.07	13.10	12.76	12.04	12.97
IPLV (According to ARI conditions 44°F leaving water temperature, 95°C entering air temperature)	MBH/kW	14.71	14.71	14.88	14.74	14.47	14.43	14.74
Compressor								
Quantity		2	2	2	2	2	2	2
Nominal Size (1)	tons	60/60	60/70	70/70	70/85	85/85	85/100	100/100
Evaporator								
Evaporator Model		H140	H155	H170	H185	H200	H220	H240
Water Storage	gal.	30	32	34	36	39	39	42
Minimum Flow	gpm	206	222	206	222	254	222	254
Maximum Flow	gpm	697	777	729	777	872	777	872
Number of water passes		2	2	2	2	2	2	2
Condenser								
Quantity of Coils		4	4	4	4	4	4	4
Coil Length	ft	13/13	15/13	15/15	18/15	18/18	21/18	21/21
Coil Height	ft	3.5	3.5	3.5	3.5	3.5	3.5	3.5
Fin series	fins/ft	192	192	192	192	192	192	192
Number of Rows		3	3	3	3	3	3	3
Condenser Fans								
Quantity (1)		4/4	5/4	5/5	6/5	6/6	7/6	7/7
Diameter	in.	30	30	30	30	30	30	30
Total Air Flow	cfm	75051	82975	90900	99990	109080	118170	127281
Nominal RPM		915	915	915	915	915	915	915
Tip Speed	ft/s	120	120	120	120	120	120	120
Motor kW	kW	1.57	1.57	1.57	1.57	1.57	1.57	1.57
Minimum Starting/Operating Ambient (2)								
Standard Unit	°F	32	32	32	32	32	32	32
Low-Ambient Unit	°F	0	0	0	0	0	0	0
General Unit								
Refrigerant		HFC 134a	HFC 134a	HFC 134a	HFC 134a	HFC 134a	HFC 134a	HFC 134a
Number of Independent Refrigerant Circuits		2	2	2	2	2	2	2
% Minimum Load (3)		17	17	17	17	17	17	17
Operating Weight (4)	lb	9814	9942	9964	11396	11948	13211	13457
Shipping Weight (4)	lb	9913	10010	10050	11466	11992	13257	13477

Notes:

1. Data containing information on two circuits shown as follows: ckt1/ckt2
2. Minimum start-up/operation ambient based on a 2.22 m/s (5mph) wind across the condenser.
3. Percent minimum load is for total machine at 10°C (50°F) ambient and 7°C (44°F) leaving chilled water temperature, not each individual circuit.
4. With aluminium fins.
5. At Eurovent conditions, 7°C leaving water temperature and 35°C entering condenser air temperature.
6. Ratings based on sea level altitude and evaporator fouling factor of 0.044 m²K/kW
7. Unit kW input, including fans

General Data

English Units

Table G-15 - General Data RTAC 120-200 Extra Efficiency

Size		120	130	140	155	175	185	200
Cooling capacity (5) (6)	kW	121.4	135.0	148.1	161.0	179.9	193.2	212.4
Power input (7)	kW	135.1	149.7	164.8	179.8	198.4	215.7	236.4
Energy Efficiency Ratio (5) (6) (as Eurovent)	kW/kW	10.78	10.82	10.78	10.75	10.88	10.75	10.78
ESEER (as Eurovent)	kW/kW	13.38	13.18	13.38	13.11	13.89	13.49	13.31
IPLV (According to ARI conditions 44°F leaving water temperature, 95°C entering air temperature)	kW/kW	15.06	15.09	15.09	15.02	15.36	15.12	15.16
Compressor								
Quantity		2	2	2	2	2	2	2
Nominal Size (1)	tons	60/60	60/70	70/70	70/85	70/100	85/100	100/100
Evaporator								
Evaporator Model		H140	H155	H170	H185	H220	H220	H240
Water Storage	l	30	32	34	36	39	39	42
Minimum Flow	l/s	206	222	206	222	222	222	254
Maximum Flow	l/s	697	777	729	777	777	777	872
Number of water passes		2	2	2	2	2	2	2
Condenser								
Quantity of Coils		4	4	4	4	4	4	4
Coil Length	mm	15/15	15/15	15/15	18/18	18/18	21/18	21/21
Coil Height	mm	3.5	3.5	3.5	3.5	3.5	3.5	3.5
Fin series	fins/ft	192	192/180	180	192/180	192/180	192	192
Number of Rows		3	3/4	4	3/4	3/4	3/4	4
Condenser Fans								
Quantity (1)		4/4	5/4	5/5	6/5	6/6	7/6	7/7
Diameter	mm	30	30	30	30	30	30	30
Total Air Flow	m ³ /s	78848	89464	88108	107349	116185	125254	123368
Nominal RPM		915	915	915	915	915	915	915
Tip Speed	m/s	120	120	120	120	120	120	120
Motor kW		1.57	1.57	1.57	1.57	1.57	1.57	1.57
Minimum Starting/Operating Ambient (2)								
Standard Unit	°C	32	32	32	32	32	32	32
Low-Ambient Unit	°C	0	0	0	0	0	0	0
General Unit								
Refrigerant		HFC 134a	HFC 134a	HFC 134a	HFC 134a	HFC 134a	HFC 134a	HFC 134a
Number of Independent Refrigerant Circuits		2	2	2	2	2	2	2
% Minimum Load (3)		17	17	17	17	17	17	17
Operating Weight (4)	kg	10505	10366	10149	11772	12852	13875	14293
Shipping Weight (4)	kg	10289	10932	10932	9913	9913	10129	11152

Notes:

1. Data containing information on two circuits shown as follows: ckt1/ckt2
2. Minimum start-up/operation ambient based on a 2.22 m/s (5mph) wind across the condenser.
3. Percent minimum load is for total machine at 10°C (50°F) ambient and 7°C (44°F) leaving chilled water temperature, not each individual circuit.
4. With aluminium fins.
5. At Eurovent conditions, 7°C leaving water temperature and 35°C entering condenser air temperature.
6. Ratings based on sea level altitude and evaporator fouling factor of 0.044 m²K/kW
7. Unit kW input, including fans

General Data

English Units

Table G-16 - General Data RTAC 140-200 Low Noise Standard

Size		140	155	170	185	200
Cooling capacity (5) (6)	tons	132.5	144.7	157.7	174.7	192.8
Power input (7)	kW	178.2	196.1	214.9	234.3	254.6
Energy Efficiency Ratio (5) (6) (as Eurovent)	MBH/kW	8.91	8.87	8.80	8.94	9.08
ESEER (as Eurovent)	MBH/kW	12.42	12.04	11.98	11.91	12.15
IPLV (According to ARI conditions 44°F leaving water temperature, 95°C entering air temperature)	MBH/kW	13.96	13.78	13.75	13.61	14.02
Compressor						
Quantity		2	2	2	2	2
Nominal Size (1)	tons	70/70	70/85	85/85	85/100	100/100
Evaporator						
Evaporator Model		H140	H155	H170	H185	H200
Water Storage	gal.	30	32	34	36	39
Minimum Flow	gpm	206	222	206	222	254
Maximum Flow	gpm	697	777	729	777	872
Number of water passes		2	2	2	2	2
Condenser						
Quantity of Coils		4	4	4	4	4
Coil Length	ft	13/13	15/13	15/15	18/15	18/18
Coil Height	ft	3.5	3.5	3.5	3.5	3.5
Fin series	fins/ft	192	192	192	192	192
Number of Rows		3	3	3	3	3
Condenser Fans						
Quantity (1)		4/4	5/4	5/5	6/5	6/6
Diameter	in.	30	30	30	30	30
Total Air Flow	cfm	56129	61808	67465	74203	80962
Nominal RPM		680	680	680	680	680
Tip Speed	ft/s	90	90	90	90	90
Motor kW	kW	0.75	0.75	0.75	0.75	0.75
Minimum Starting/Operating Ambient (2)						
Standard Unit °C	°F	32	32	32	32	32
Low-Ambient Unit °C	°F	0	0	0	0	0
General Unit						
Refrigerant		HFC 134a	HFC 134a	HFC 134a	HFC 134a	HFC 134a
Number of Independent Refrigerant Circuits		2	2	2	2	2
% Minimum Load (3)		17	17	17	17	17
Operating Weight (4)	lb	9858	10250	10547	11805	12074
Shipping Weight (4)	lb	9955	10320	10635	11878	12118

Notes:

1. Data containing information on two circuits shown as follows: ckt1/ckt2
2. Minimum start-up/operation ambient based on a 2.22 m/s (5mph) wind across the condenser.
3. Percent minimum load is for total machine at 10°C (50°F) ambient and 7°C (44°F) leaving chilled water temperature, not each individual circuit.
4. With aluminium fins.
5. At Eurovent conditions, 7°C leaving water temperature and 35°C entering condenser air temperature.
6. Ratings based on sea level altitude and evaporator fouling factor of 0.044 m²K/kW
7. Unit kW input, including fans

General Data

English Units

Table G-17 - General Data RTAC 120-200 High Efficiency Low Noise

Size		120	130	140	155	170	185	200
Cooling capacity (5) (6)	tons	115.2	127.3	140.3	152.3	165.0	183.1	202.3
Power input (7)	kW	141	155.1	169.8	186.8	204.3	223.8	244.2
Energy Efficiency Ratio (5) (6) (as Eurovent)	MBH/kW	9.83	9.86	9.93	9.79	9.69	9.83	9.93
ESEER (as Eurovent)	MBH/kW	12.90	12.90	13.07	13.03	12.83	12.80	12.97
IPLV (According to ARI conditions 44°F leaving water temperature, 95°C entering air temperature)	MBH/kW	14.74	14.71	14.98	14.77	14.60	14.50	14.84
Compressor								
Quantity		2	2	2	2	2	2	2
Nominal Size (1)	tons	60/60	60/70	70/70	70/85	85/85	85/100	100/100
Evaporator								
Evaporator Model		H140	H155	H170	H185	H200	H220	H240
Water Storage	gal.	30	32	34	36	39	39	42
Minimum Flow	gpm	206	222	206	222	254	222	254
Maximum Flow	gpm	697	777	729	777	872	777	872
Number of water passes		2	2	2	2	2	2	2
Condenser								
Quantity of Coils		4	4	4	4	4	4	4
Coil Length	ft	13/13	15/13	15/15	18/15	18/18	21/18	21/21
Coil Height	ft	3.5	3.5	3.5	3.5	3.5	3.5	3.5
Fin series	fins/ft	192	192	192	192	192	192	192
Number of Rows		3	3	3	3	3	3	3
Condenser Fans								
Quantity (1)		4/4	5/4	5/5	6/5	6/6	7/6	7/7
Diameter	in.	30	30	30	30	30	30	30
Total Air Flow	cfm	56066	61723	67380	74097	80835	87595	94354
Nominal RPM		680	680	680	680	680	680	680
Tip Speed	ft/s	90	90	90	90	90	90	90
Motor kW	kW	0.75	0.75	0.75	0.75	0.75	0.75	0.75
Minimum Starting/Operating Ambient (2)								
Standard Unit	°F	32	32	32	32	32	32	32
Low-Ambient Unit	°F	0	0	0	0	0	0	0
General Unit								
Refrigerant		HFC 134a	HFC 134a	HFC 134a	HFC 134a	HFC 134a	HFC 134a	HFC 134a
Number of Independent Refrigerant Circuits		2	2	2	2	2	2	2
% Minimum Load (3)		17	17	17	17	17	17	17
Operating Weight (4)	lb	9814	9942	9964	11396	11948	13211	13457
Shipping Weight (4)	lb	9913	10010	10050	11466	11992	13257	13477

Notes:

1. Data containing information on two circuits shown as follows: ckt1/ckt2
2. Minimum start-up/operation ambient based on a 2.22 m/s (5mph) wind across the condenser.
3. Percent minimum load is for total machine at 10°C (50°F) ambient and 7°C (44°F) leaving chilled water temperature, not each individual circuit.
4. With aluminium fins.
5. At Eurovent conditions, 7°C leaving water temperature and 35°C entering condenser air temperature.
6. Ratings based on sea level altitude and evaporator fouling factor or 0.044 m²K/kW
7. Unit kW input, including fans

General Data

English Units

Table G-18 - General Data RTAC 120-200 Extra Efficiency Low Noise

Size		120	130	140	155	175	184	200
Cooling capacity (5) (6)	tons	117.3	130.6	142.6	156.0	174.0	186.8	204.4
Power input (7)	kW	135.1	149.7	164.8	179.8	198.4	215.7	236.4
Energy Efficiency Ratio (5) (6) (as Eurovent)	MBH/kW	10.4	10.5	10.4	10.4	10.5	10.4	10.4
ESEER (as Eurovent)	MBH/kW	13.5	13.3	13.4	13.6	14.2	13.7	13.2
IPLV (According to ARI conditions 44°F leaving water temperature, 95°C entering air temperature)	MBH/kW	15.3	15.4	15.2	15.5	15.8	15.4	15.1
Compressor								
Quantity		2	2	2	2	2	2	2
Nominal Size (1)	tons	60/60	60/70	70/70	70/85	70/100	85/100	100/100
Evaporator								
Evaporator Model		H140	H155	H170	H185	H220	H220	H240
Water Storage	gal.	30	32	34	36	39	39	42
Minimum Flow	gpm	206	222	206	222	222	222	254
Maximum Flow	gpm	697	777	729	777	777	777	872
Number of water passes		2	2	2	2	2	2	2
Condenser								
Quantity of Coils		4	4	4	4	4	4	4
Coil Length	ft	15/15	15/15	15/15	18/18	18/18	21/18	21/21
Coil Height	ft	3.5	3.5	3.5	3.5	3.5	3.5	3.5
Fin series	fins/ft	192	192/180	180	192/180	192/180	192	192
Number of Rows		3	3/4	4	3/4	3/4	3/4	4
Condenser Fans								
Quantity (1)		4/4	5/4	5/5	6/5	6/6	7/6	7/7
Diameter	in.	30	30	30	30	30	30	30
Total Air Flow	cfm	59607	66007	64714	79187	85671	92410	90608
Nominal RPM		680	680	680	680	680	680	680
Tip Speed	ft/s	90	90	90	90	90	90	90
Motor kW	kW	0.75	0.75	0.75	0.75	0.75	0.75	0.75
Minimum Starting/Operating Ambient (2)								
Standard Unit	°F	32	32	32	32	32	32	32
Low-Ambient Unit	°F	0	0	0	0	0	0	0
General Unit								
Refrigerant		HFC 134a	HFC 134a	HFC 134a	HFC 134a	HFC 134a	HFC 134a	HFC 134a
Number of Independent Refrigerant Circuits		2	2	2	2	2	2	2
% Minimum Load (3)		17	17	17	17	17	17	17
Operating Weight (4)	lb	10505	10366	10149	11772	12852	13875	14293
Shipping Weight (4)	lb	10289	10932	10932	9913	9913	10129	11152

Notes:

1. Data containing information on two circuits shown as follows: ckt1/ckt2
2. Minimum start-up/operation ambient based on a 2.22 m/s (5mph) wind across the condenser.
3. Percent minimum load is for total machine at 10°C (50°F) ambient and 7°C (44°F) leaving chilled water temperature, not each individual circuit.
4. With aluminium fins.
5. At Eurovent conditions, 7°C leaving water temperature and 35°C entering condenser air temperature.
6. Ratings based on sea level altitude and evaporator fouling factor of 0.044 m²K/kW
7. Unit kW input, including fans

General Data

English Units

Table G-19 - General Data RTAC 230-400 Standard

Size		230	240	250	275	300	350	375	400
Cooling capacity (5) (6)	tons	218.9	244.0	242.0	269.4	306.4	338.9	376.1	412.8
Power input (7)	kW	263	293.6	293.4	330.5	370.2	418.9	458.8	498.4
Energy Efficiency Ratio (5) (6) (as Eurovent)	MBH/kW	10.00	9.96	9.89	9.79	9.93	9.72	9.83	9.93
ESEER (as Eurovent)	MBH/kW	13.44	14.23	13.03	13.17	13.44	13.99	14.13	14.26
IPLV (According to ARI conditions 44°F leaving water temperature, 95°C entering air temperature)	MBH/kW	14.71	14.84	13.82	13.82	13.55	15.25	15.35	15.49
Compressor									
Quantity		3	3	3	3	3	4	4	4
Nominal Size (1)	tons	60-60/100	70-70/100	70-70/100	85-85/100	100-100/100	85-85/85-85	100-100/85-85	100-100/100-100
Evaporator									
Evaporator Model		EH270	EH270	EH250	EH270	EH301	EH340	EH370	EH401
Water Storage	gal.	59	59	52	59	63	70	74	78
Minimum Flow	gpm	317	317	269	317	349	349	380	412
Maximum Flow	gpm	1125	1125	951	1125	1120	1268	1379	1458
Number of water passes		2	2	2	2	2	2	2	2
Condenser									
Quantity of Coils		2/2	2/2	4/4	4/4	4/4	4/4	4/4	4/4
Coil Length	ft	21/21	21/21	13/9	15/9	18/9	15/15	18/15	18/18
Coil Height	ft	3.5	3.5	3.5	3.5	3.5	3.5	3.5	3.5
Fin series	fins/ft	192	180	192	192	192	192	192	192
Number of Rows		3	4	3	3	3	3	3	3
Condenser Fans									
Quantity (1)		7/7	7/7	8/6	10/6	12/6	10/10	12/10	12/12
Diameter	in.	30	30	30	30	30	30	30	30
Total Air Flow	cfm	127324	123467	129697	145567	163768	181969	200171	218372
Nominal RPM		915	915	915	915	915	915	915	915
Tip Speed	ft/s	120	120	120	120	120	120	120	120
Motor kW	kW	1.57	1.57	1.57	1.57	1.57	1.57	1.57	1.57
Minimum Starting/Operating Ambient (2)									
Standard Unit	°F	32	32	32	32	32	32	32	32
Low-Ambient Unit	°F	0	0	0	0	0	0	0	0
General Unit									
Refrigerant		HFC 134a	HFC 134a	HFC 134a	HFC 134a	HFC 134a	HFC 134a	HFC 134a	HFC 134a
Number of Independent Refrigerant Circuits		2	2	2	2	2	2	2	2
% Minimum Load (3)		13	13	13	13	13	10	10	10
Operating Weight (4)	lb	17688	17688	17508	19239	20841	23714	25159	26512
Shipping Weight (4)	lb	16852	17072	17204	18878	20451	23357	24814	26138

Notes:

1. Data containing information on two circuits shown as follows: ckt1/ckt2
2. Minimum start-up/operation ambient based on a 2.22 m/s (5mph) wind across the condenser.
3. Percent minimum load is for total machine at 10°C (50°F) ambient and 7°C (44°F) leaving chilled water temperature, not each individual circuit.
4. With aluminium fins.
5. At Eurovent conditions, 7°C leaving water temperature and 35°C entering condenser air temperature.
6. Ratings based on sea level altitude and evaporator fouling factor of 0.044 m²K/kW
7. Unit kW input, including fans

General Data

English Units

Table G-20 - General Data RTAC 250-400 High Efficiency

Size		250	275	300	350	375	400
Cooling capacity (5) (6)	tons	249.4	278.3	316.2	349.2	387.9	427.0
Power input (7)	kW	289.8	321	360.2	407.2	446.9	486.9
Energy Efficiency Ratio (5) (6) (as Eurovent)	MBH/kW	10.34	10.41	10.54	10.30	10.41	10.54
ESEER (as Eurovent)	MBH/kW	13.10	13.65	13.92	13.96	14.09	14.26
IPLV (According to ARI conditions 44°F leaving water temperature, 95°C entering air temperature)	MBH/kW	13.99	14.84	15.18	15.15	15.25	15.49
Compressor							
Quantity		3	3	3	4	4	4
Nominal Size (1)	tons	70-70/100	85-85/100	100-100/100	85-85/85-85	100-100/85-85	100-100/100-100
Evaporator							
Evaporator Model		EH300	EH320	EH321	EH400	EH440	EH480
Water Storage	gal.	63	68	68	78	80	86
Minimum Flow	gpm	349	380	380	412	428	460
Maximum Flow	gpm	1220	1363	1363	1458	1537	1664
Number of water passes		2	2	2	2	2	2
Condenser							
Quantity of Coils		4/4	4/4	4/4	4/4	4/4	4/4
Coil Length	ft	15/9	18/12	21/12	18/18	21/18	21/21
Coil Height	ft	3.5	3.5	3.5	3.5	3.5	3.5
Fin series	fins/ft	192	192	192	192	192	192
Number of Rows		3	3	3	3	3	3
Condenser Fans							
Quantity (1)		10/6	12/6	14/6	12/12	14/12	14/14
Diameter	in.	30	30	30	30	30	30
Total Air Flow	cfm	145482	169404	187606	218160	236361	254583
Nominal RPM		915	915	915	915	915	915
Tip Speed	ft/s	120	120	120	120	120	120
Motor kW	kW	1.57	1.57	1.57	1.57	1.57	1.57
Minimum Starting/Operating Ambient (2)							
Standard Unit	°F	32	32	32	32	32	32
Low-Ambient Unit	°F	0	0	0	0	0	0
General Unit							
Refrigerant		HFC 134a	HFC 134a	HFC 134a	HFC 134a	HFC 134a	HFC 134a
Number of Independent Refrigerant Circuits		2	2	2	2	2	2
% Minimum Load (3)		13	13	13	10	10	10
Operating Weight (4)	lb	18568	21600	22741	26613	27779	29315
Shipping Weight (4)	lb	17204	21171	22310	26233	27355	28840

Notes:

1. Data containing information on two circuits shown as follows: ckt1/ckt2
2. Minimum start-up/operation ambient based on a 2.22 m/s (5mph) wind across the condenser.
3. Percent minimum load is for total machine at 10°C (50°F) ambient and 7°C (44°F) leaving chilled water temperature, not each individual circuit.
4. With aluminium fins.
5. At Eurovent conditions, 7°C leaving water temperature and 35°C entering condenser air temperature.
6. Ratings based on sea level altitude and evaporator fouling factor or 0.044 m²K/kW
7. Unit kW input, including fans

General Data

English Units

Table G-21 - General Data RTAC 255-400 Extra Efficiency

Size		255	275	300	355	375	400
Cooling capacity (5) (6)	tons	255.5	283.8	320.8	366.8	394.7	431.3
Power input (7)	kW	283.5	318.9	355.9	408.2	444.9	481.5
Energy Efficiency Ratio (5) (6) (as Eurovent)	MBH/kW	10.8	10.7	10.8	10.8	10.6	10.7
ESEER (as Eurovent)	MBH/kW	13.5	13.7	14.1	14.2	14.4	14.4
IPLV (According to ARI conditions 44°F leaving water temperature, 95°C entering air temperature)	MBH/kW	15.1	15.1	15.4	15.4	15.6	15.6
Compressor							
Quantity		3	3	3	4	4	4
Nominal Size (1)	tons	70-70/100	85-85/100	100-100/100	70-70/100-100	100-100/85-85	100-100/100-100
Evaporator							
Evaporator Model		EH300	EH320	EH321	EH440	EH480	EH480
Water Storage	gal.	63	68	68	80	86	86
Minimum Flow	gpm	349	380	380	428	460	460
Maximum Flow	gpm	1220	1363	1363	1537	1664	1664
Number of water passes		2	2	2	2	2	2
Condenser							
Quantity of Coils		4/4	4/4	4/4	4/4	4/4	4/4
Coil Length	ft	13/13	13/14	13/15	13/16	13/17	13/18
Coil Height	ft	3.5	3.5	3.5	3.5	3.5	3.5
Fin series	fins/ft	180	180	180	180	180	180
Number of Rows		4	4	4	4	4	4
Condenser Fans							
Quantity (1)		10/6	12/6	14/6	12/12	14/12	14/14
Diameter	in.	30	30	30	30	30	30
Total Air Flow	cfm	147080	176174	193804	211476	229276	246652
Nominal RPM		915	915	915	915	915	915
Tip Speed	ft/s	120	120	120	120	120	120
Motor kW	kW	1.57	1.57	1.57	1.57	1.57	1.57
Minimum Starting/Operating Ambient (2)							
Standard Unit	°F	32	32	32	32	32	32
Low-Ambient Unit	°F	0	0	0	0	0	0
General Unit							
Refrigerant		HFC 134a	HFC 134a	HFC 134a	HFC 134a	HFC 134a	HFC 134a
Number of Independent Refrigerant Circuits		2	2	2	2	2	2
% Minimum Load (3)		13	13	13	10	10	10
Operating Weight (4)	lb	20988	22640	24121	25749	29113	30983
Shipping Weight (4)	lb	20759	22370	23855	25769	29031	30864

Notes:

1. Data containing information on two circuits shown as follows: ckt1/ckt2
2. Minimum start-up/operation ambient based on a 2.22 m/s (5mph) wind across the condenser.
3. Percent minimum load is for total machine at 10°C (50°F) ambient and 7°C (44°F) leaving chilled water temperature, not each individual circuit.
4. With aluminium fins.
5. At Eurovent conditions, 7°C leaving water temperature and 35°C entering condenser air temperature.
6. Ratings based on sea level altitude and evaporator fouling factor of 0.044 m²K/kW
7. Unit kW input, including fans

General Data

English Units

Table G-22 - General Data RTAC 230-400 Low Noise Standard

Size		230	240	250	275	300	350	375	400
Cooling capacity (5) (6)	tons	207.3	227.0	229.4	255.3	290.6	320.6	356.2	391.3
Power input (7)	kW	271.9	309.6	306.7	344.6	385.7	437	478.5	519.6
Energy Efficiency Ratio (5) (6) (as Eurovent)	MBH/kW	9.14	8.80	8.97	8.91	9.04	8.80	8.94	9.04
ESEER (as Eurovent)	MBH/kW	13.85	14.09	12.39	13.27	13.72	14.81	14.91	15.15
IPLV (According to ARI conditions 44°F leaving water temperature, 95°C entering air temperature)	MBH/kW	15.25	15.39	14.09	14.23	13.85	16.10	16.28	16.55
Compressor									
Quantity		3	3	3	3	3	4	4	4
Nominal Size (1)	tons	60-60/100	70-70/100	70-70/100	85-85/100	100-100/100	85-85/85-85	100-100/85-85	100-100/100-100
Evaporator									
Evaporator Model		EH270	EH270	EH250	EH270	EH301	EH340	EH370	EH401
Water Storage	gal.	59	59	52	59	63	70	74	78
Minimum Flow	gpm	317	317	269	317	349	349	380	412
Maximum Flow	gpm	1125	1125	951	1125	1220	1268	1379	1458
Number of water passes		2	2	2	2	2	2	2	2
Condenser									
Quantity of Coils		2/2	2/2	4/4	4/4	4/4	4/4	4/4	4/4
Coil Length	ft	21/21	21/21	13/9	15/9	18/9	15/15	18/15	18/18
Coil Height	ft	3.5	3.5	3.5	3.5	3.5	3.5	3.5	3.5
Fin series	fins/ft	192	180	192	192	192	192	192	192
Number of Rows		3	4	3	3	3	3	3	3
Condenser Fans									
Quantity (1)		7/7	7/7	8/6	10/6	12/6	10/10	12/10	12/12
Diameter	in.	30	30	30	30	30	30	30	30
Total Air Flow	cfm	94396	90730	96621	107957	121454	134951	148449	161946
Nominal RPM		680	680	680	680	680	680	680	680
Tip Speed	ft/s	90	90	90	90	90	90	90	90
Motor kW	kW	0.75	0.75	0.75	0.75	0.75	0.75	0.75	0.75
Minimum Starting/Operating Ambient (2)									
Standard Unit	°F	32	32	32	32	32	32	32	32
Low-Ambient Unit	°F	0	0	0	0	0	0	0	0
General Unit									
Refrigerant		HFC 134a	HFC 134a	HFC 134a	HFC 134a	HFC 134a	HFC 134a	HFC 134a	HFC 134a
Number of Independent Refrigerant Circuits		2	2	2	2	2	2	2	2
% Minimum Load (3)		13	13	13	13	13	10	10	10
Operating Weight (4)	lb	17688	17688	17508	19239	20841	23714	25159	26512
Shipping Weight (4)	lb	16852	17072	17204	18878	20451	23357	24814	26138

Notes:

1. Data containing information on two circuits shown as follows: ckt1/ckt2
2. Minimum start-up/operation ambient based on a 2.22 m/s (5mph) wind across the condenser.
3. Percent minimum load is for total machine at 10°C (50°F) ambient and 7°C (44°F) leaving chilled water temperature, not each individual circuit.
4. With aluminium fins.
5. At Eurovent conditions, 7°C leaving water temperature and 35°C entering condenser air temperature.
6. Ratings based on sea level altitude and evaporator fouling factor of 0.044 m²K/kW
7. Unit kW input, including fans

General Data

English Units

Table G-23 - General Data RTAC 250-400 High Efficiency Low Noise

Size		250	275	300	350	375	400
Cooling capacity (5) (6)	tons	238.5	267.6	304.0	335.4	372.6	410.2
Power input (7)	kW	299	328.3	368.9	415.6	456.6	498.1
Energy Efficiency Ratio (5) (6) (as Eurovent)	MBH/kW	9.59	9.79	9.89	9.69	9.79	9.89
ESEER (as Eurovent)	MBH/kW	13.27	14.06	14.33	15.15	15.22	15.46
IPLV (According to ARI conditions 44°F leaving water temperature, 95°C entering air temperature)	MBH/kW	14.09	14.88	14.47	16.45	16.58	16.86
Compressor							
Quantity		3	3	3	4	4	4
Nominal Size (1)	tons	70-70/100	85-85/100	100-100/100	85-85/85-85	100-100/85-85	100-100/100-100
Evaporator							
Evaporator Model		EH300	EH320	EH321	EH400	EH440	EH480
Water Storage	gal.	63	68	68	78	80	86
Minimum Flow	gpm	349	380	380	412	428	460
Maximum Flow	gpm	1220	1363	1363	1458	1537	1664
Number of water passes		2	2	2	2	2	2
Condenser							
Quantity of Coils		4/4	4/4	4/4	4/4	4/4	4/4
Coil Length	ft	15/9	18/12	21/12	18/18	21/18	21/21
Coil Height	ft	3.5	3.5	3.5	3.5	3.5	3.5
Fin series	fins/ft	192	192	192	192	192	192
Number of Rows		3	3	3	3	3	3
Condenser Fans							
Quantity (1)		10/6	12/6	14/6	12/12	14/12	14/14
Diameter	in.	30	30	30	30	30	30
Total Air Flow	cfm	107872	126667	140164	161713	175210	188729
Nominal RPM		680	680	680	680	680	680
Tip Speed	ft/s	90	90	90	90	90	90
Motor kW	kW	0.75	0.75	0.75	0.75	0.75	0.75
Minimum Starting/Operating Ambient (2)							
Standard Unit	°F	32	32	32	32	32	32
Low-Ambient Unit	°F	0	0	0	0	0	0
General Unit							
Refrigerant		HFC 134a	HFC 134a	HFC 134a	HFC 134a	HFC 134a	HFC 134a
Number of Independent Refrigerant Circuits		2	2	2	2	2	2
% Minimum Load (3)		13	13	13	10	10	10
Operating Weight (4)	lb	18568	21600	22741	26613	27779	29315
Shipping Weight (4)	lb	17204	21171	22310	26233	27355	28840

Notes:

1. Data containing information on two circuits shown as follows: ckt1/ckt2
2. Minimum start-up/operation ambient based on a 2.22 m/s (5mph) wind across the condenser.
3. Percent minimum load is for total machine at 10°C (50°F) ambient and 7°C (44°F) leaving chilled water temperature, not each individual circuit.
4. With aluminium fins.
5. At Eurovent conditions, 7°C leaving water temperature and 35°C entering condenser air temperature.
6. Ratings based on sea level altitude and evaporator fouling factor of 0.044 m²K/kW
7. Unit kW input, including fans

General Data

English units

Table G-24 - General Data RTAC 255-400 Extra Efficiency Low Noise

Size		255	275	300	355	375	400
Cooling capacity (5) (6)	tons	246.6	274.8	310.0	352.5	379.4	414.2
Power input (7)	kW	292.1	324.3	363.4	418.8	455.4	495.5
Energy Efficiency Ratio (5) (6) (as Eurovent)	MBH/kW	10.1	10.2	10.2	10.1	10.0	10.0
ESEER (as Eurovent)	MBH/kW	13.8	15.0	15.1	15.3	15.7	15.6
IPLV (According to ARI conditions 44°F leaving water temperature, 95°C entering air temperature)	MBH/kW	15.4	15.6	15.2	16.0	17.0	16.9
Compressor							
Quantity		3	3	3	4	4	4
Nominal Size (1)	tons	70-70/100	85-85/100	100-100/100	70-70/100-100	100-100/85-85	100-100/100-100
Evaporator							
Evaporator Model		EH300	EH320	EH321	EH440	EH480	EH480
Water Storage	gal.	63	68	68	80	86	86
Minimum Flow	gpm	349	380	380	428	460	460
Maximum Flow	gpm	1220	1363	1363	1537	1664	1664
Number of water passes		2	2	2	2	2	2
Condenser							
Quantity of Coils		4/4	4/4	4/4	4/4	4/4	4/4
Coil Length	ft	13/13	13/14	13/15	13/16	13/17	13/18
Coil Height	ft	3.5	3.5	3.5	3.5	3.5	3.5
Fin series	fins/ft	180	180	180	180	180	180
Number of Rows		4	4	4	4	4	4
Condenser Fans							
Quantity (1)		10/6	12/6	14/6	12/12	14/12	14/14
Diameter	in.	30	30	30	30	30	30
Total Air Flow	cfm	109213	129365	142333	155344	168270	181238
Nominal RPM		680	680	680	680	680	680
Tip Speed	ft/s	90	90	90	90	90	90
Motor kW	kW	0.75	0.75	0.75	0.75	0.75	0.75
Minimum Starting/Operating Ambient (2)							
Standard Unit	°F	32	32	32	32	32	32
Low-Ambient Unit	°F	-0.4	-0.4	-0.4	-0.4	-0.4	-0.4
General Unit							
Refrigerant		HFC 134a	HFC 134a	HFC 134a	HFC 134a	HFC 134a	HFC 134a
Number of Independent Refrigerant Circuits		2	2	2	2	2	2
% Minimum Load (3)		13	13	13	10	10	10
Operating Weight (4)	lb	20988	22640	24121	25749	29113	30983
Shipping Weight (4)	lb	20759	22370	23855	25769	29031	30864

Notes:

1. Data containing information on two circuits shown as follows: ckt1/ckt2
2. Minimum start-up/operation ambient based on a 2.22 m/s (5mph) wind across the condenser.
3. Percent minimum load is for total machine at 10°C (50°F) ambient and 7°C (44°F) leaving chilled water temperature, not each individual circuit.
4. With aluminium fins.
5. At Eurovent conditions, 7°C leaving water temperature and 35°C entering condenser air temperature.
6. Ratings based on sea level altitude and evaporator fouling factor of 0.044 m²/K/kW
7. Unit kW input, including fans

Performance Data

Figure P-18 - Evaporator Water Pressure Drop (SI)

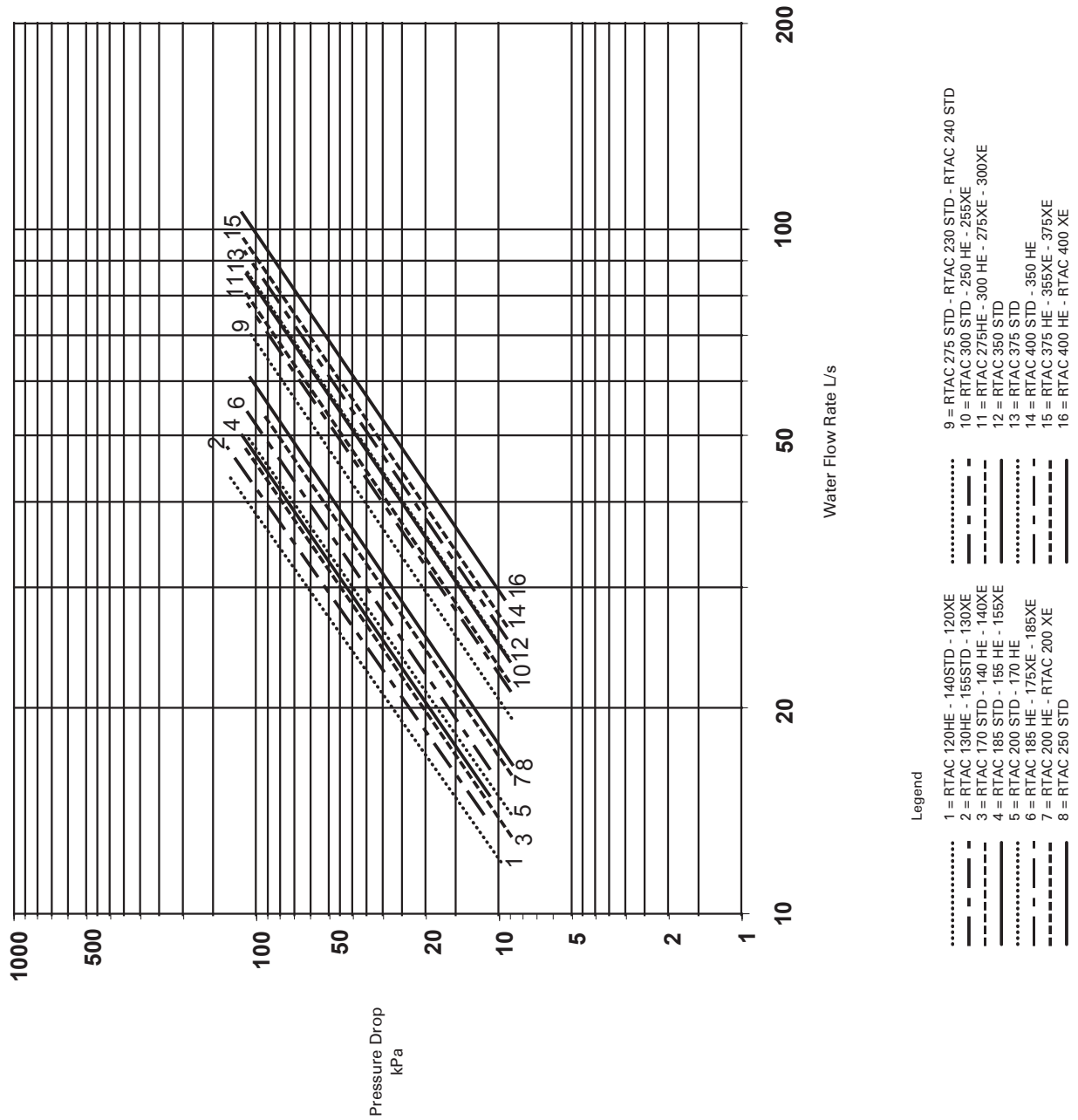

Performance Data

Figure P-19 - Water Side Pressure Drop (English Units)

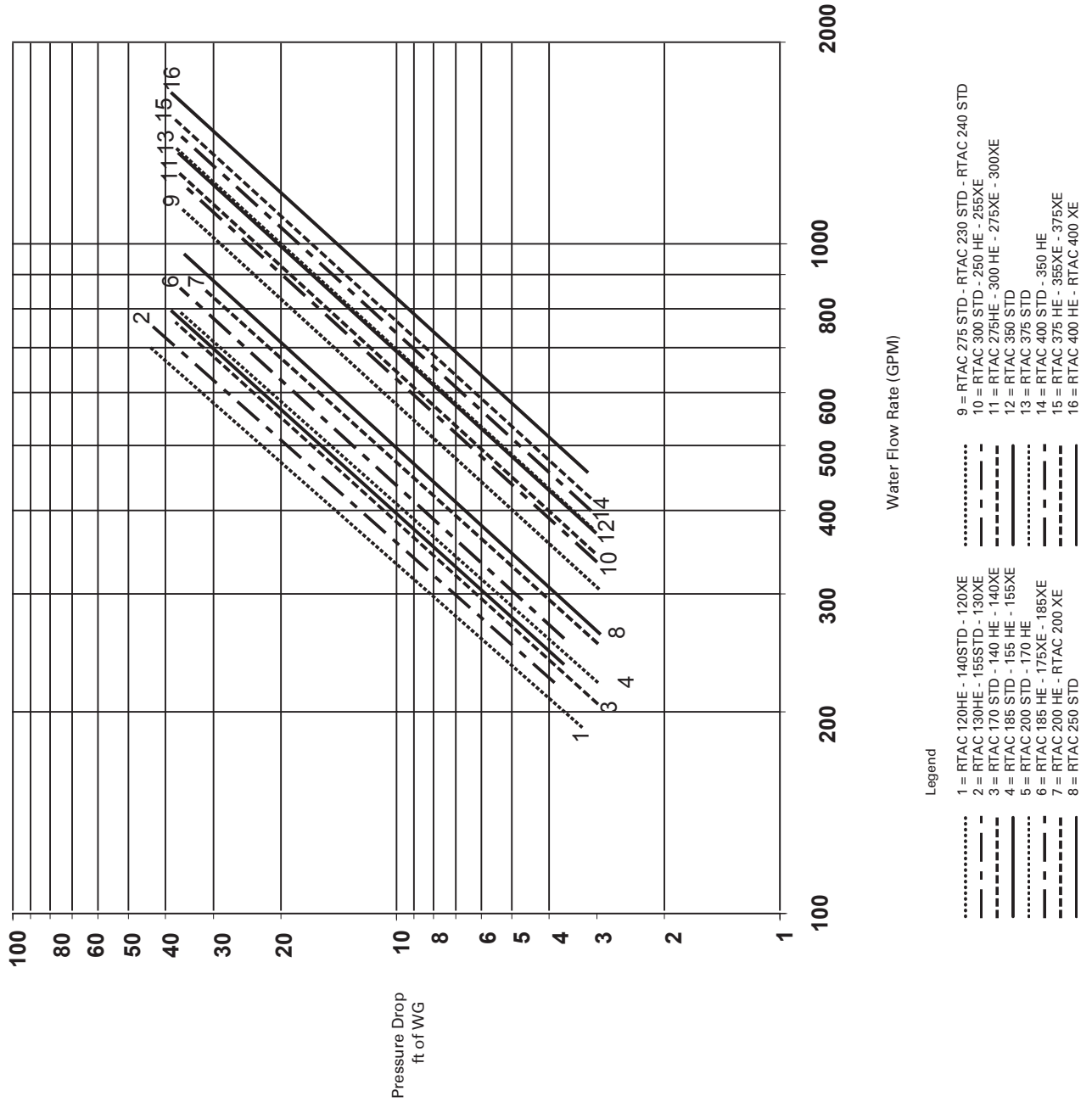

Controls



Figure 7 - Dyna View

Safety Controls

A centralized microcomputer offers a higher level of machine protection. Because the safety controls are smarter, they limit compressor operation in order to avoid compressor or evaporator failures, thereby minimizing nuisance shutdowns. Tracer™ Chiller Controls directly senses the control variables that govern the operation of the chiller: motor current draw, evaporator pressure, condenser pressure. When any one of these variables approaches a limit condition at which the unit may be damaged or shut down on a safety, Tracer Chiller Controls takes corrective action to avoid shutdown and keep the chiller operating. It does this through combined actions of compressor slide-valve modulation, electronic expansion-valve modulation, and fan staging. Tracer Chiller Controls optimizes total chiller power consumption during normal operating conditions. During abnormal operating conditions, the microprocessor will continue to optimize chiller performance by taking the corrective action necessary to avoid shutdown. This keeps cooling capacity available until the problem can be solved. Whenever possible, the chiller is allowed to perform its function: make chilled water. In addition, microcomputer controls allow for more types of protection, such as over and under voltage! (option) Overall, the safety controls help keep the building or process running and out of trouble.

Stand-alone controls

Interfacing to stand-alone units is very simple: only a remote auto/stop for scheduling is required for unit operation. Signals from the chilled-water pump contactor auxiliary, or a flow switch, are wired to the chilled-water flow interlock. Signals from a time clock or some other remote device are wired to the external auto/stop input.

Tracer™ Chiller Control human interfaces

Standard Features

External Auto/Stop

A job-site-provided contact closure will turn the unit on and off.

Chilled Waterflow Interlock

A job-site-provided contact closure from a chilled-water pump contactor, or a flow switch, is required and will allow unit operation if a load exists. This feature will allow the unit to run in conjunction with the pump system.

External Interlock

A job-site-provided contact opening wired to this input will turn the unit off and require a manual reset of the unit microcomputer. This closure is typically triggered by a job-site-provided system such as a fire alarm.

Chilled Water Pump Control

Unit controls provide an output to control the chilled-water pump(s). One contact closure to the chiller is all that is required to initiate the chilled-water system. Chilled water pump control by the chiller is a requirement on all the Air-Cooled Series R Chillers.

Controls

Alarm Indication Contacts

Four factory-installed contacts with the following preset default assignments:

- Alarm
- Chiller running
- Maximum capacity
- Chiller limit.

Additional Features that May Be Added

(require some optional factory-installed hardware)

- Ice-making card
- Tracer communication card
- Chilled water and remote current-limit set point card.

Note: All wiring outside the unit is supplied by the contractor.

Easy Interface to a Generic Building Management System

Controlling the air-cooled Series R chiller with building management systems is state-of-the-art, yet simple with either the LonTalk Communications Interface for Chillers (LCI-C) or Generic Building Management System Hardware Points.

Simple Interface with Other Control Systems

Microcomputer controls afford simple interface with other control systems, such as time clocks, building automation systems, and ice storage systems. This means you have the flexibility to meet job requirements while not having to learn a complicated control system. This setup has the same standard features as a stand-alone water chiller, with the possibility of having additional optional features.

What are LonTalk, Echelon, and LonMark?

LonTalk is a communications protocol developed by the Echelon Corporation. The LonMark association develops control profiles using the LonTalk communication protocol. LonTalk is a unit level communications protocol, unlike BACNet used at the system level.

LonTalk Communications Interface for Chillers (LCI-C)

LonTalk Communications Interface for Chillers (LCI-C) provides a generic automation system with the LonMark chiller profile inputs/outputs. The inputs/ outputs include both mandatory and optional network variables. Note: LonMark network variable names are in parentheses when different from chiller naming convention.

Chiller Inputs:

- Chiller Enable/Disable
- Chilled Liquid Setpoint (Cool Setpoint)
- Current Limit Setpoint (Capacity Limit Input)
- Ice Making (Chiller Mode)

Chiller Enable/Disable

Allows for chiller to be started or stopped depending on if certain operating conditions are met.

Chilled Liquid Setpoint

Allows for the external setting independent of the front panel setpoint to adjust the leaving water temperature setpoint.

Current Limit Setpoints

Allows for the external setting independent of the front panel setpoint to limit the capacity level of the chiller.

Ice Making

Provides interface with ice making control systems. Please refer to page 9 for more information.

Chiller Outputs:

- On/Off o Active Setpoint
- Average Percent RLA (Actual Capacity Level)
- Active Current Limit Setpoint (Capacity Limit)
- Leaving Chilled Water Temperature
- Entering Chilled Water Temperature
- Alarm Descriptor
- Chiller Status

Controls

On/Off

Indicates the current state of the chiller

Active Setpoint

Indicates the current value of the leaving water temperature setpoint

Average Percent RLA

Provides the current capacity level via %RLA

Active Current Limit Setpoint

Provides the current capacity level setpoint via %RLA

Leaving Chilled Water Temperature

Provides the current leaving water temperature

Entering Chilled Water Temperature

Provides the current entering water temperature

Alarm Descriptor

Provides alarm messages based on predetermined criteria

Chiller Status

Indicates the running modes and states of the chiller, i.e. Running in alarm mode, chiller enabled, chiller being locally controlled, etc...

Generic Building Management System

Hardware Points

GBAS may be achieved via hardware input/output as well. The input/outputs are as follows:

Chiller hardware inputs include:

- Chiller enable/disable
- Circuit enable/disable
- External chilled water setpoint - option
- External current limit setpoint - option
- Ice making enable - option

External Chilled Water Setpoint - option

Allows the external setting independent of the front panel setpoint by one of two means:

- a) 2-10 VDC input, or
- b) 4-20 mA input

External Current Limit Setpoint - option

Allows the external setting independent of the front panel setpoint by one of two means:

- a) 2-10 VDC input, or
- b) 4-20 mA input

Chiller hardware outputs include:

- Compressor running indication
- Alarm indication (Ckt1/Ckt 2)
- Maximum capacity
- Ice making status

Alarm Indication Contacts

The unit provides three single-pole/double-throw contact closures to indicate:

- a) Compressor on/off status
- b) Compressor running at maximum capacity
- c) Failure has occurred (Ckt 1/Ckt 2)

These contact closures may be used to trigger jobsite supplied alarm lights or alarm bells.

Ice Making Control - option

Provides interface with ice making control systems.

Controls

Tracer Summit™ Controls — Interface with the Trane Integrated Comfort System (ICS)

Trane Chiller Plant Control

The Tracer Chiller Plant Manager building management system provides building automation and energy management functions through stand-alone control. The Chiller Plant Control is capable of monitoring and controlling your entire chiller plant system.

Application software available:

- Time-of-day scheduling
- Demand limiting
- Chiller sequencing
- Process control language
- Boolean processing
- Zone control
- Reports and logs
- Custom messages
- Run time and maintenance
- Trend log
- PID control loops

And of course, the Trane Chiller Plant Control can be used on a stand-alone basis or tied into a complete building automation system.

When the air-cooled Series R™ chiller is used in conjunction with a Trane Tracer Summit™ system, the unit can be monitored and controlled from a remote location. The air-cooled Series R chiller can be controlled to fit into the overall building automation strategy by using time-of-day scheduling, timed override, demand limiting, and chiller sequencing. A building owner can completely monitor the air-cooled Series R chiller from the Tracer system, since all of the monitoring information indicated on the microcomputer can be read on the unit controllers Tracer system display. In addition, all the powerful diagnostic information can be read back at the Tracer system. Best of all, this powerful capability comes over a single twisted pair of wires! Air-cooled Series R chillers can interface with many different external control systems, from

simple stand-alone units to ice-making systems. Each unit requires a single-source, three-phase power supply and a 115-volt power supply. The 115-volt supply handles the freeze protection for the evaporator heaters.

A single twisted pair of wires tied directly between the air-cooled Series R™ chiller and a Tracer Summit™ system provides control, monitoring, and diagnostic capabilities. Control functions include auto/stop, adjustment of leaving-water-temperature set point, compressor operation lockout for kW demand limiting, and control of ice-making mode. The Tracer system reads monitoring information such as entering- and leaving-evaporator-water temperatures and outdoor air temperature. Over 60 individual diagnostic codes can be read by the Tracer system. In addition, the Tracer system can provide sequencing control for up to 25 units on the same chilled-water loop. Pump sequencing control can be provided from the Tracer system. Tracer ICS is not available in conjunction with the external set point capability.

Required Options

Tracer Interface

Additional Options that May Be Used

Ice-Making Control

External Trane Devices Required

Tracer Summit™, Tracer 100 System or Tracer Chiller Plant Control

Ice-Making Systems Controls

An ice-making option may be ordered with the air-cooled Series R™ chiller. The unit will have two operating modes, ice making and normal daytime cooling. In the ice-making mode, the air-cooled Series R chiller will operate at full compressor capacity until the return chilled-fluid temperature entering the evaporator meets the ice-making set point. Two input signals are required to the air-cooled Series R chiller for the ice-making option.

The first is an auto/stop signal for scheduling, and the second is required to switch the unit between the ice-making mode and normal daytime operation. The signals are provided by a remote job site building-automation device such as a time clock or a manual switch. In addition, the signals may be provided over the twisted wire pair from a Tracer™ system, or a LonTalk Communication Interface but will require the communication boards provided with the Ice Making Control Option.

Additional Options That May Be Used

Failure Indication Contacts
 Communications Interface (For Tracer Systems)
 Chilled-Water Temperature Reset

Wire Sizing

Table J-1 - Customer Wire Selection RTAC 120 - 200

Voltage 400/3/50	Unit without Disconnect Switch	Unit with Disconnect Switch	
	Wire Selection Size to Main Terminal Block	Wire Selection Size to Disconnect Switch	
Unit Size	Maximum cable size mm ²	Disconnect Switch size (Amps)	Maximum cable size mm ²
Standard			
140	2x240	625	2x240
155	2x240	925	2x240
170	2x240	925	2x240
185	2x240	925	2x240
200	2x240	925	2x240
Standard Low Noise			
140	2x240	625	2x240
155	2x240	925	2x240
170	2x240	925	2x240
185	2x240	925	2x240
200	2x240	925	2x240
High Efficiency and 200 Extra Efficiency			
120	2x240	625	2x240
130	2x240	625	2x240
140	2x240	625	2x240
155	2x240	925	2x240
170	2x240	925	2x240
185	2x240	925	2x240
200	2x240	925	2x240
High Efficiency Low Noise and 200 Extra Efficiency Low Noise			
120	2x240	625	2x240
130	2x240	625	2x240
140	2x240	625	2x240
155	2x240	925	2x240
170	2x240	925	2x240
185	2x240	925	2x240
200	2x240	925	2x240
Extra Efficiency			
120	2x240 mm ²	6x250 + 3x125	2x240 mm ²
130	2x240 mm ²	6x250 + 3x125	2x240 mm ²
140	2x240 mm ²	6x250 + 3x125	2x240 mm ²
155	2x240 mm ²	6x400 + 3x125	2x240 mm ²
175	2x240 mm ²	6x400 + 3x125	2x240 mm ²
185	2x240 mm ²	6x400 + 3x125	2x240 mm ²
200	2x240 mm ²	6x400 + 3x125	2x240 mm ²
Extra Efficiency Low Noise			
120	2x240 mm ²	6x250 + 3x125	2x240 mm ²
130	2x240 mm ²	6x250 + 3x125	2x240 mm ²
140	2x240 mm ²	6x250 + 3x125	2x240 mm ²
155	2x240 mm ²	6x400 + 3x125	2x240 mm ²
175	2x240 mm ²	6x400 + 3x125	2x240 mm ²
185	2x240 mm ²	6x400 + 3x125	2x240 mm ²
200	2x240 mm ²	6x400 + 3x125	2x240 mm ²

Wire Sizing

Table J-2 - Customer Wire Selection RTAC 230 - 400

Voltage 400/3/50	Unit without Disconnect Switch	Unit with Disconnect Switch	
	Wire Selection Size to Main Terminal Block	Wire Selection Size to Disconnect Switch	
Unit Size	Maximum cable size mm ²	Disconnect Switch size (Amps)	Maximum cable size mm ²
Standard			
230	4x240	3x160A + 6x250A + 3x400A	6x240
240	4x240	3x160A + 6x250A + 3x400A	6x240
250	4x240	3x160A + 6x250A + 3x400A	6x240
275	4x240	3x160A + 6x250A + 3x400A	6x240
300	4x240	3x160A + 9x400A	6x240
350	4x240	3x160A + 12x250A	6x240
375	4x240	3x160A + 6x400A + 6x250A	6x240
400	4x240	3x160A + 12x400A	6x240
Standard Low Noise			
230	4x240	3x160A + 6x250A + 3x400A	6x240
240	4x240	3x160A + 6x250A + 3x400A	6x240
250	4x240	3x160A + 6x250A + 3x400A	6x240
275	4x240	3x160A + 6x250A + 3x400A	6x240
300	4x240	3x160A + 9x400A	6x240
350	4x240	3x160A + 12x250A	6x240
375	4x240	3x160A + 6x400A + 6x250A	6x240
400	4x240	3x160A + 12x400A	6x240
High Efficiency and 400 Extra Efficiency			
250	4x240	3x160A + 6x250A + 3x400A	6x240
275	4x240	3x160A + 6x250A + 3x400A	6x240
300	4x240	3x160A + 9x400A	6x240
350	4x240	3x160A + 12x250A	6x240
375	4x240	3x160A + 6x400A + 6x250A	6x240
400	4x240	3x160A + 12x400A	6x240
High Efficiency Low Noise and 400 Extra Efficiency Low Noise			
250	4x240	3x160A + 6x250A + 3x400A	6x240
275	4x240	3x160A + 6x250A + 3x400A	6x240
300	4x240	3x160A + 9x400A	6x240
350	4x240	3x160A + 12x250A	6x240
375	4x240	3x160A + 6x400A + 6x250A	6x240
400	4x240	3x160A + 12x400A	6x240
Extra Efficiency			
255	4x240	3x160A + 6x250A + 3x400A	6x240
275	4x240	3x160A + 6x250A + 3x400A	6x240
300	4x240	3x160A + 9x400A	6x240
355	4x240	3x160A + 6x400A + 6x250A	6x240
375	4x240	3x160A + 6x400A + 6x250A	6x240
400	4x240	3x160A + 12x400A	6x240
Extra Efficiency Low Noise			
255	4x240	3x160A + 6x250A + 3x400A	6x240
275	4x240	3x160A + 6x250A + 3x400A	6x240
300	4x240	3x160A + 9x400A	6x240
355	4x240	3x160A + 6x400A + 6x250A	6x240
375	4x240	3x160A + 6x400A + 6x250A	6x240
400	4x240	3x160A + 12x400A	6x240

Note: the material for cables and busbar is copper.

Electrical Data

Table E-1 - Electrical Data RTAC 120 - 200 (400/3/50)

Unit Size	Quantity	Compressor (Each)				Motor Data				Fans (Each) (6)		Evaporator heater	
		Maximum Amps (3)		Starting Amps (4)		Quantity	kW	FLA	Fan fuse size (A)	Control (VA)	A	kW	
		cmpr 1	cmpr 2	cmpr 1	cmpr 2								
Standard													
140	2	178	178	259	259	8	1.57	3.5	80	860	2.15	2.04	
155	2	214	178	291	259	9	1.57	3.5	80	860	2.15	2.04	
170	2	214	214	291	291	10	1.57	3.5	80	860	2.15	2.04	
185	2	259	214	354	291	11	1.57	3.5	80	860	2.15	2.04	
200	2	259	259	354	354	12	1.57	3.5	80	860	2.15	2.04	
Standard Low Noise													
140	2	178	178	259	259	8	1.57	2.0	80	860	2.15	2.04	
155	2	214	178	291	259	9	1.57	2.0	80	860	2.15	2.04	
170	2	214	214	291	291	10	1.57	2.0	80	860	2.15	2.04	
185	2	259	214	354	291	11	1.57	2.0	80	860	2.15	2.04	
200	2	259	259	354	354	12	1.57	2.0	80	860	2.15	2.04	
High Efficiency													
120	2	147	147	217	217	8	1.57	3.5	80	860	2.15	2.04	
130	2	178	147	259	217	9	1.57	3.5	80	860	2.15	2.04	
140	2	178	178	259	259	10	1.57	3.5	80	860	2.15	2.04	
155	2	214	178	291	259	11	1.57	3.5	80	860	2.15	2.04	
170	2	214	214	291	291	12	1.57	3.5	80	860	2.15	2.04	
185	2	259	214	354	291	13	1.57	3.5	80	860	2.15	2.04	
200	2	259	259	354	354	14	1.57	3.5	80	860	2.15	2.04	
High Efficiency Low Noise													
120	2	147	147	217	217	8	0.75	2.0	80	860	2.15	2.04	
130	2	178	147	259	217	9	0.75	2.0	80	860	2.15	2.04	
140	2	178	178	259	259	10	0.75	2.0	80	860	2.15	2.04	
155	2	214	178	291	259	11	0.75	2.0	80	860	2.15	2.04	
170	2	214	214	291	291	12	0.75	2.0	80	860	2.15	2.04	
185	2	259	214	354	291	13	0.75	2.0	80	860	2.15	2.04	
200	2	259	259	354	354	14	0.75	2.0	80	860	2.15	2.04	
Extra Efficiency													
120	2	147	147	217	217	8	1.57	3.5	80	860	2.15	2.04	
130	2	178	147	259	217	10	1.57	3.5	80	860	2.15	2.04	
140	2	178	178	259	259	10	1.57	3.5	80	860	2.15	2.04	
155	2	214	178	291	259	12	1.57	3.5	80	860	2.15	2.04	
175	2	259	178	354	259	13	1.57	3.5	80	860	2.15	2.04	
185	2	259	214	354	291	14	1.57	3.5	80	860	2.15	2.04	
200	2	259	259	354	354	14	1.57	3.5	80	860	2.15	2.04	
Extra Efficiency Low Noise													
120	2	147	147	217	217	8	0.75	2.0	80	860	2.15	2.04	
130	2	178	147	259	217	10	0.75	2.0	80	860	2.15	2.04	
140	2	178	178	259	259	10	0.75	2.0	80	860	2.15	2.04	
155	2	214	178	291	259	12	0.75	2.0	80	860	2.15	2.04	
175	2	259	178	354	259	13	0.75	2.0	80	860	2.15	2.04	
185	2	259	214	354	291	14	0.75	2.0	80	860	2.15	2.04	
200	2	259	259	354	354	14	0.75	2.0	80	860	2.15	2.04	

Notes:

1. Maximum Compressors FLA + all fans FLA + control Amps
2. Starting Amps of the circuit with the largest compressor circuit including fans plus RLA of the second circuit including fans and control amps
3. Maximum FLA per compressor
4. Compressors starting amps, Star delta start
5. Compressor Power Factor
6. High static fans data - 100Pa ESP - Quantity same as standard fans, power input = 2.21kW each, FLA = 3.9 each

Electrical Data

Table E-1 - Electrical Data RTAC 230 - 400 (400/3/50)

Unit size	Quantity	Compressor (Each)												Fans (Each) (6)				
		Maximum Amps (3)				Starting Amps (4)				Starting amps, Direct on line start (7)				Quantity	kW	FLA	Fans fuse size (A)	Control (VA)
		cmpr 1	cmpr 2	cmpr 3	cmpr 4	cmpr 1	cmpr 2	cmpr 3	cmpr 4	cmpr 1	cmpr 2	cmpr 3	cmpr 4					
Standard																		
230	3	147	147	259	-	217	217	354	-	668	668	1089		14	1.57	3.5	50/50	1720
240	3	178	178	259	-	259	259	354	-	796	796	1089		14	1.57	3.5	50/50	1720
250	3	178	178	259	-	259	259	354	-	796	796	1089		14	1.57	3.5	50/50	1720
275	3	214	214	259	-	291	291	354	-	896	896	1089		16	1.57	3.5	50/50	1720
300	3	259	259	259	-	354	354	354	-	1089	1089	1089		18	1.57	3.5	63/50	1720
350	4	214	214	214	214	291	291	291	291	896	896	896	896	20	1.57	3.5	50/50	1720
375	4	259	259	214	214	354	354	291	291	1089	1089	896	896	22	1.57	3.5	63/50	1720
400	4	259	259	259	259	354	354	354	354	1089	1089	1089	1089	24	1.57	3.5	63/63	1720
Standard Low Noise																		
230	3	147	147	259	-	217	217	354	-	668	668	1089		14	0.75	2.0	50/50	1720
240	3	178	178	259	-	259	259	354	-	796	796	1089		14	0.75	2.0	50/50	1720
250	3	178	178	259	-	259	259	354	-	796	796	1089		14	0.75	2.0	50/50	1720
275	3	214	214	259	-	291	291	354	-	896	896	1089		16	0.75	2.0	50/50	1720
300	3	259	259	259	-	354	354	354	-	1089	1089	1089		18	0.75	2.0	63/50	1720
350	4	214	214	214	214	291	291	291	291	896	896	896	896	20	0.75	2.0	50/50	1720
375	4	259	259	214	214	354	354	291	291	1089	1089	896	896	22	0.75	2.0	63/50	1720
400	4	259	259	259	259	354	354	354	354	1089	1089	1089	1089	24	0.75	2.0	63/63	1720
High Efficiency																		
250	3	178	178	259	-	259	259	354	-	796	796	1089		16	1.57	3.5	50/50	1720
275	3	214	214	259	-	291	291	354	-	896	896	1089		18	1.57	3.5	63/50	1720
300	3	259	259	259	-	354	354	354	-	1089	1089	1089		20	1.57	3.5	80/50	1720
350	4	214	214	214	214	291	291	291	291	896	896	896	896	24	1.57	3.5	63/63	1720
375	4	259	259	214	214	354	354	291	291	1089	1089	896	896	26	1.57	3.5	80/63	1720
400	4	259	259	259	259	354	354	354	354	1089	1089	1089	1089	28	1.57	3.5	80/80	1720
High Efficiency Low Noise																		
250	3	178	178	259	-	259	259	354	-	796	796	1089		16	0.75	2.0	50/50	1720
275	3	214	214	259	-	291	291	354	-	896	896	1089		18	0.75	2.0	63/50	1720
300	3	259	259	259	-	354	354	354	-	1089	1089	1089		20	0.75	2.0	80/50	1720
350	4	214	214	214	214	291	291	291	291	896	896	896	896	24	0.75	2.0	63/63	1720
375	4	259	259	214	214	354	354	291	291	1089	1089	896	896	26	0.75	2.0	80/63	1720
400	4	259	259	259	259	354	354	354	354	1089	1089	1089	1089	28	0.75	2.0	80/80	1720
Extra Efficiency																		
255	3	178	178	259	-	259	259	354	-	796	796	1089		16	1.57	3.5	50/50	1720
275	3	214	214	259	-	291	291	354	-	896	896	1089		20	1.57	3.5	63/50	1720
300	3	259	259	259	-	354	354	354	-	1089	1089	1089		22	1.57	3.5	80/50	1720
355	4	259	259	178	178	354	354	259	259	1089	1089	796	796	24	1.57	3.5	80/63	1720
375	4	259	259	214	214	354	354	291	291	1089	1089	896	896	26	1.57	3.5	80/63	1720
400	4	259	259	259	259	354	354	354	354	1089	1089	1089	1089	28	1.57	3.5	80/80	1720
Extra Efficiency Low Noise																		
255	3	178	178	259	-	259	259	354	-	796	796	1089		16	0.75	2.0	50/50	1720
275	3	214	214	259	-	291	291	354	-	896	896	1089		20	0.75	2.0	63/50	1720
300	3	259	259	259	-	354	354	354	-	1089	1089	1089		22	0.75	2.0	80/50	1720
355	4	259	259	178	178	354	354	259	259	1089	1089	796	796	24	0.75	2.0	80/63	1720
375	4	259	259	214	214	354	354	291	291	1089	1089	896	896	26	0.75	2.0	80/63	1720
400	4	259	259	259	259	354	354	354	354	1089	1089	1089	1089	28	0.75	2.0	80/80	1720

Electrical Data

Table E-2 - Electrical Data RTAC 120 - 200 Unit Wiring (400/3/50)

Motor Data								
Unit size	Number of Power Connections	Maximum Amps (1)	Compressor (Each)			Power Factor (5)	Compressor Fuse Size (A)	Short Circuit Rating (kA)
			Starting Amps (2)	Starting Amps (2) (7) Direct on line start	Starting Amps (2) (7) Direct on line start			
Standard								
140	1	386	424	961	0.89	200-200	35	
155	1	426	460	1065	0.89	315-250	35	
170	1	465	490	1095	0.89	315-315	35	
185	1	514	557	1292	0.89	315-315	35	
200	1	562	594	1329	0.89	315-315	35	
230	1	606	629	1364	0.89	250-250/315	35	
240	1	668	677	1412	0.89	250-250/315	35	
250	1	668	677	1412	0.89	250-250/315	35	
275	1	747	738	1473	0.89	250-250/315	35	
300	1	844	813	1548	0.89	315-315/315	35	
350	1	930	851	1456	0.89	250-250/250-250	35	
375	1	1027	955	1690	0.89	315-315/250-250	35	
400	1	1124	1030	1765	0.89	315-315/315-315	35	
Standard Low Noise								
140	1	374	412	949	0.89	200-200	35	
155	1	412	446	1051	0.89	315-250	35	
170	1	450	475	1080	0.89	315-315	35	
185	1	497	540	1275	0.89	315-315	35	
200	1	544	576	1311	0.89	315-315	35	
230	1	585	608	1343	0.89	250-250/315	35	
240	1	647	656	1391	0.89	250-250/315	35	
250	1	647	656	1391	0.89	250-250/315	35	
275	1	723	714	1449	0.89	250-250/315	35	
300	1	817	786	1521	0.89	315-315/315	35	
350	1	900	821	1426	0.89	250-250/250-250	35	
375	1	994	922	1657	0.89	315-315/250-250	35	
400	1	1088	994	1729	0.89	315-315/315-315	35	
High Efficiency								
120	1	324	358	809	0.89	200-200	35	
130	1	359	404	941	0.89	200-200	35	
140	1	393	431	968	0.89	200-200	35	
155	1	433	467	1072	0.89	315-250	35	
170	1	472	497	1102	0.89	315-315	35	
185	1	521	564	1299	0.89	315-315	35	
200	1	569	601	1336	0.89	315-315	35	
250	1	675	684	1419	0.89	250-250/315	35	
275	1	754	745	1480	0.89	250-250/315	35	
300	1	851	820	1551	0.89	315-315/315	35	
350	1	944	865	1470	0.89	250-250/250-250	35	
375	1	1041	969	1704	0.89	315-315/250-250	35	
400	1	1138	1044	1779	0.89	315-315/315-315	35	

Electrical Data

Table E-2 - Electrical Data RTAC 120 - 200 Unit Wiring (400/3/50)

Unit size	Number of Power Connections	Maximum Amps (1)	Motor Data		Power Factor (5)	Compressor Fuse Size (A)	Short Circuit Rating (kA)
			Starting Amps (2)	Starting Amps (2) (7) Direct on line start			
Compressor (Each)							
Standard							
High Efficiency Low Noise							
120	1	312	346	797	0.89	200-200	35
130	1	345	390	927	0.89	200 -200	35
140	1	378	416	953	0.89	200-200	35
155	1	416	450	1055	0.89	315-250	35
170	1	454	479	1084	0.89	315-315	35
185	1	501	544	1279	0.89	315-315	35
200	1	548	580	1315	0.89	315-315	35
250	1	651	660	1395	0.89	250-250/315	35
275	1	727	718	1453	0.89	250-250/315	35
300	1	821	790	1525	0.89	315-315/315	35
350	1	908	829	1434	0.89	250-250/250-250	35
375	1	1002	930	1665	0.89	315-315/250-250	35
400	1	1096	1002	1737	0.89	315-315/315-315	35
Extra Efficiency							
120	1	324	358	809	0.89	200-200	35
130	1	362	407	944	0.89	200 -200	35
140	1	393	431	968	0.89	200-200	35
155	1	436	470	1075	0.89	315-250	35
175	1	485	537	1272	0.89	315-250	35
185	1	524	567	1302	0.89	315-315	35
200	1	569	601	1336	0.89	315-315	35
255	1	675	684	1419	0.89	250-250/315	35
275	1	761	752	1487	0.89	250-250/315	35
300	1	858	827	1562	0.89	315-315/315	35
355	1	962	908	1643	0.89	315-315/250-250	35
375	1	1041	969	1704	0.89	315-315/250-250	35
400	1	1138	1044	1779	0.89	315-315/315-315	35
Extra Efficiency Low Noise							
120	1	312	346	797	0.89	200-200	35
130	1	347	392	929	0.89	200 -200	35
140	1	378	416	953	0.89	200-200	35
155	1	418	452	1057	0.89	315-250	35
175	1	465	517	1252	0.89	315-250	35
185	1	503	546	1281	0.89	315-315	35
200	1	548	580	1315	0.89	315-315	35
255	1	651	660	1395	0.89	250-250/315	35
275	1	731	722	1457	0.89	250-250/315	35
300	1	825	794	1529	0.89	315-315/315	35
355	1	926	872	1607	0.89	315-315/250-250	35
375	1	1002	930	1665	0.89	315-315/250-250	35
400	1	1096	1002	1737	0.89	315-315/315-315	35

Dimensional Data

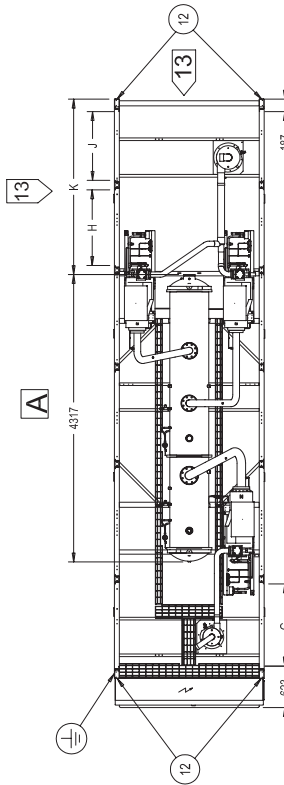
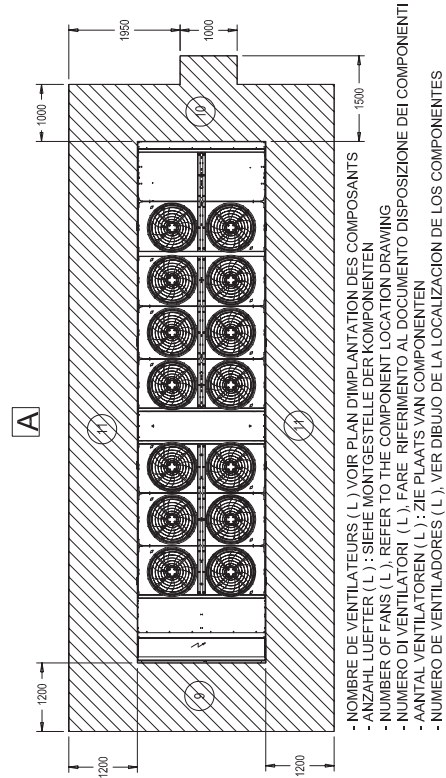

RTAC	A	B	C	D	E	F	G	H	J	K	L	M
250 SE	9138	2030	2150	2030	1500	1620	1234	1135	1032	2634	14	5
250 HE	9138	2030	2150	2030	1500	1620	1234	1272	982	2634	16	5
255 XE	10056	2032	2032	2032	1732	1503	1578	1272	982	3112	16	6
275 SE	9138	2030	2150	2030	1500	1620	1234	1272	982	2629	16	5
275 HE	10975	1905	2794	1905	1923	1656	1578	1652	1258	3108	18	6
275 XE	10975	1905	2794	1905	1923	1656	1578	1652	1258	3108	20	6
300 SE	10056	2032	2032	2032	1732	1503	1234	1625	1258	2951	18	6
300 HE	11894	2161	2921	2161	2208	1811	1578	1858	1769	3650	20	6
300 XE	11894	2161	2921	2161	2208	1811	1578	1858	1769	3650	22	6

RTAC 250-275-300 50Hz

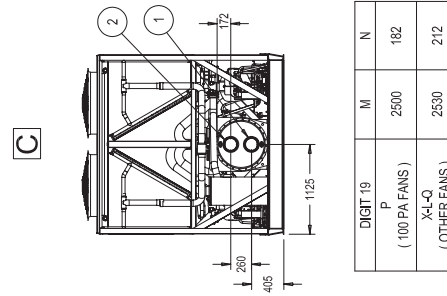
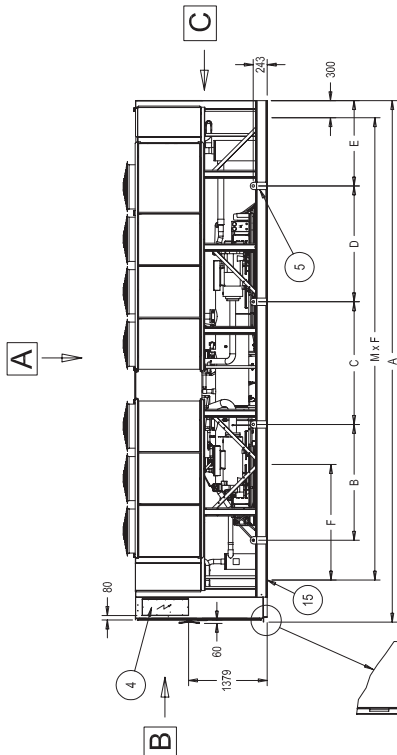

DIGIT 19	M	N
P (100 PA FANS)	2500	182
X-L-Q (OTHER FANS)	2530	212

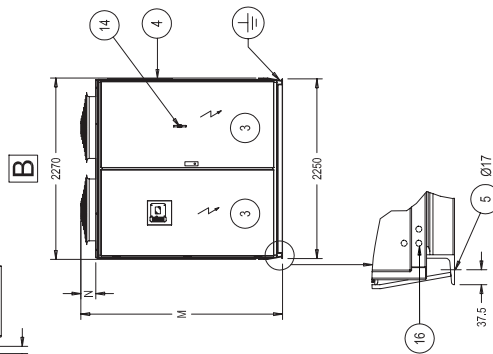

Dimensional Data

TRANE RTAC 350-375-400 50Hz

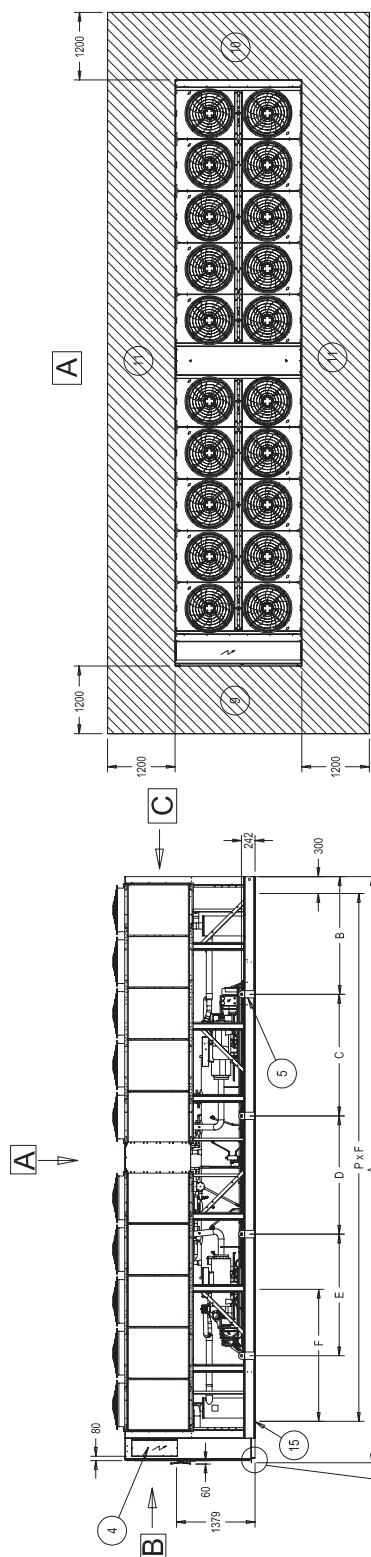

- NOMBRE DE VENTILATEURS (N) : VOIR PLAN D'IMPLANTATION DES COMPOSANTS
- ANZAHL LUEFTER (N) : SIEHE MONTGESTELLE DER KOMONENTEN
- NUMBER OF FANS (N) : REFER TO THE COMPONENT LOCATION DRAWING
- NUMERO DI VENTILATORI (N) : FARE RIFERIMENTO AL DOCUMENTO DISPOSIZIONE DEI COMPONENTI
- AMTAL VENTILATOREN (N) : ZIE PLATIS VAN COMPONENTEN
- NUMERO DE VENTILADORES (N) : VER DIBUJO DE LA LOCALIZACION DE LOS COMPONENTES

C

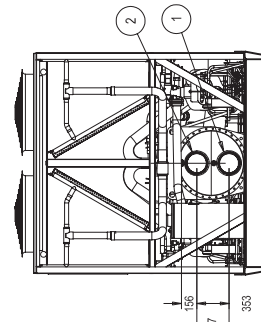

DIGIT 19	P	Q
P (100 PA FANS)	2500	182
X-L-Q (OTHER FANS)	2500	212

B

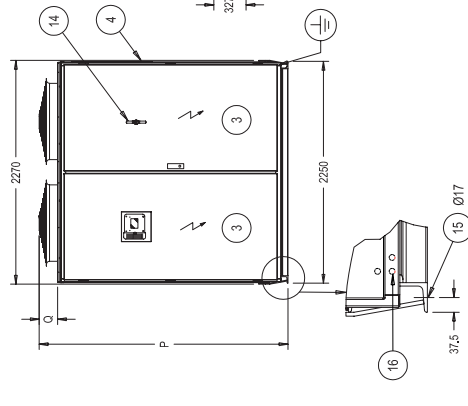

RTAC	A	B	C	D	E	F	G	H	J	K	L	M	N	P
350 SE	10406	2089	2159	2100	2159	1339	2933	982	1272	1140	982	1272	20	7
350 HE	12244	2435	2330	2900	2330	1402	3852	1258	1652	1652	1258	1652	24	8
355 XE	12244	2435	2330	2900	2330	1402	3852	1814	1812	1662	982	1272	24	8
375 SE	11325	2520	2159	2591	2159	1285	3852	1258	1652	1652	982	1272	22	8
375 HE	13163	3034	2513	2667	2513	1516	4771	1814	1812	1662	1258	1652	26	8
375 XE	13163	3034	2513	2667	2513	1516	4771	1814	1812	1662	1258	1652	26	8
400 SE	12244	2435	2330	2900	2330	1402	3852	1652	1652	1652	1258	1652	24	8
400 HE	14082	3212	2620	2600	2620	1631	4771	1814	1812	1662	1814	1812	28	8
400 XE	14082	3212	2620	2600	2620	1631	4771	1814	1812	1662	1814	1812	28	8

Dimensional Data

RTAC 250-400



REFROIDISSEURS DE LIQUIDE / WASSERKUEHLMASCHINEN / LIQUID CHILLERS

1	CONNEXION ENTRE DEAU EVAPORATEUR	WASSERANTRITTS-VERDAMPFER	EVAPORATOR WATER INLET CONNECTION
2	CONNEXION SORTIE DEAU EVAPORATEUR	WASSERAUSTRITTS-VERDAMPFER	EVAPORATOR WATER OUTLET CONNECTION
3	ARMOIRE ELECTRIQUE	STEUERSCHRANK	ELECTRICAL PANEL
4	ACCES RACCORDEMENT CLIENT - ALIMENTATION PUISSANCE UNITE	ABDECKPLATTE FÜR BAUSITZE - KABELLEINFÜHRUNG	POWER CABLE GLAND PLATE FOR CUSTOMER WIRING
5	POINT DE LEVAGE 045	TRAMPORFÖRSEN 045	RISING EYES 045
6	MASSE EN FONCTIONNEMENT (Kg)	BETRIEBSGEWICHT (Kg)	OPERATING WEIGHT (Kg)
7	CHARGE DE FLUIDE FRIGORIGENE (Kg) R134a	KÄLTEMITTEL-FÜLLUNG (Kg) R134a	REFRIGERANT CHARGE (Kg) R134a
8	CHARGE D'HUILE (litres)	ÖL FÜLLUNG (litres)	OIL CHARGE (litres)
9	AIR CONSOLE POUR MAINTENANCE	MINDEST-WANDABSTAND (ZUR WARTUNG)	MINIMUM CLEARANCE (FOR MAINTENANCE)
10	ARE CONSIGLIEE POUR DETUBAGE DE LEVAPORATEUR	AUSSAU	MINIMUM CLEARANCE (EVAPORATOR TUBES REMOVAL)
11	ARES NECESSAIRE POUR ENTREE D'AIR	MINDEST-WANDABSTAND (LUFTEINTRITT)	MINIMUM CLEARANCE (AIR ENTERING)
12	POTEAU	SENKRECHTE STREBEN	FRAME POST
13	ACCES RACCORDEMENT/CONTROLE ET REGULATION (3 PRESSE-ETOUPIES PG 13.5)	ABDECKPLATTE FÜR BAUSITZE - STEUERVERKABELUNG (3 KABELVERSCHÜBLUNG PG 13.5)	EXTERNAL CONTROL WIRING CABLE GLAND PLATE FOR CUSTOMER WIRING (3 CABLE GLAND PG 13.5)
13 >	PASSAGE PROPOSE POUR CONNEXIONS	EMPFOHLENE KABELVERKABELUNG	RECOMMENDED CHILLED WATER PIPEWORK LAYOUT
14	SECTIONNEUR PUISSANCE	SCHALTSCHRANK HAUPTSCHALTER	POWER DISCONNECT SWITCH
15	AMORTISSEURS	DAEMPFER	ISOLATORS

OPZIONI / ZUBEHOER / OPTIONS

14	SECTIONNEUR PUISSANCE	SCHALTSCHRANK HAUPTSCHALTER	POWER DISCONNECT SWITCH
15	AMORTISSEURS	DAEMPFER	ISOLATORS

REFRIGERATO DI LIQUIDO / WATERSKOELMACHINE / ENFRIADORA DE LIQUIDO

1	COLLEGAMENTO INGRESSO ACQUA	VERDAMPFER WATERINTRITTE	CONEXION DE ENTRADA DE AGUA AL EVAPORADOR
2	COLLEGAMENTO USCITA ACQUA	VERDAMPFER WATERUITTRITTE	CONEXION DE SALIDA DE AGUA DEL EVAPORADOR
3	PANNELLO DI CONTROLLO	BESTURINGSPANEEL	PANEL DE CONTROL
4	ACCESO RACCORRI CLIENTE - ALIMENTAZIONE DI POTENZA	BUNDEPLAAT TEN BEHOEVE VAN VOEDINGSKABEL KUNST	ACCESO PARA EL CABLEADO DE FUERZA A REALIZAR POR EL CUENTE
5	GOLFARI 045	HUISOGEN 045	PUNTOS DE ELEVACION 045
6	PESO IN FUNZIONAMENTO (Kg)	BETRIJFSGEWICHT (Kg)	PESO EN OPERACION (Kg)
7	CARICA DI FLUIDO FRIGORIGENO (Kg) R134a	KOUDEMIDDELVULLING (Kg) R134a	CARGA DE REFRIGERANTE (Kg) R134a
8	CARICA D'OILIO (litri)	OLIEVULLING (litres)	CARGA DE ACEITE (litros)
9	MINIMO SPAZIO DI SERVIZIO	MINIMUM VRIJE RUIMTE (VOOR ONDERHOUD)	ESPACIO LIBRE MINIMO PARA MANTENIMIENTO
10	SPAZIO MINIMO NECESSI PER LA RIMOZIONE TUBI	MINIMUM AFSTAND (VERVANGENVERDAMPFER PIPES)	ESPACIO LIBRE PARA EXTRA
11	SPAZIO PER ARIA DI ENTRATA	MINIMALE VRIJE RUIMTE VOOR LUCHTINTRITTE	ESPACIO LIBRE MINIMO PARA TOMA DE AIRE
12	TELAIO DI SOSTEGNO	STANDAER	COLUMNA DE SOPORTE
13	ACCES RACCORRI CLIENTE CONTROLLO ESTERNO (3 PRENSI STOPPA PG 13.5)	BUNDEPLAAT TEN BEHOEVE VAN EXTERNALE STRUITSCHROMKABEL REGELINGE (3 WARTELS PG13.5)	ACCESO RACCORRI CLIENTE ALIMENTAZIONE CONTROLLO E REGOLAZIONE (3 PASSACAVI PG 13.5)
13 >	COLLEGAMENTO IDRAULICO RACCOMANDATO	AANBEVOLEN GEKOELDEWATER LEIDINGLOOP	DISTRIBUCION DE TUBERIAS DE AGUA FRIA RECOMENDADA
14	SEZIONATORE DI POTENZA	HOOFDSCHAKELAAR	SECCIONADOR DE FUERZA
15	AMMORTIZZANTI	DEMPERS	AMORTIZADORES

OPZIONI / TOEBEHOREN / OPCIONES

14	SEZIONATORE DI POTENZA	HOOFDSCHAKELAAR	SECCIONADOR DE FUERZA
15	AMMORTIZZANTI	DEMPERS	AMORTIZADORES

RTAC	Digit 18	(6) (Kg.)	(7) (Kg.)	(8) (L.)	(1) (2)
250SE	AL "Xc3-5" Cul. 2"	7595	152 + 91		
250HE	AL "Xc3-5" Cul. 2"	8779	166 + 91	18 + 9.5	
255XE	AL "Xc3-5" Cul. 2"	9339	184 + 126		
275SE	AL "Xc3-5" Cul. 2"	8745	166 + 91		
275HE	AL "Xc3-5" Cul. 2"	9818	188 + 91	18 + 9.5	6"
275XE	AL "Xc3-5" Cul. 2"	10331	205 + 126		
300SE	AL "Xc3-5" Cul. 2"	9473	188 + 91		
300HE	AL "Xc3-5" Cul. 2"	10337	209 + 91	21 + 9.5	
300XE	AL "Xc3-5" Cul. 2"	10795	230 + 126		
350SE	AL "Xc3-5" Cul. 2"	10779	166 + 166	18 + 18	
350HE	AL "Xc3-5" Cul. 2"	12097	188 + 188	18 + 18	
355XE	AL "Xc3-5" Cul. 2"	12217	230 + 164	21 + 18	
375SE	AL "Xc3-5" Cul. 2"	12666	188 + 166	21 + 18	
375HE	AL "Xc3-5" Cul. 2"	14077	209 + 168	21 + 20	8"
375XE	AL "Xc3-5" Cul. 2"	13052	230 + 205		
400SE	AL "Xc3-5" Cul. 2"	12651	188 + 188		
400HE	AL "Xc3-5" Cul. 2"	13392	209 + 209	21 + 21	
400XE	AL "Xc3-5" Cul. 2"	14883	230 + 230		
		13784	230 + 230	21 + 21	

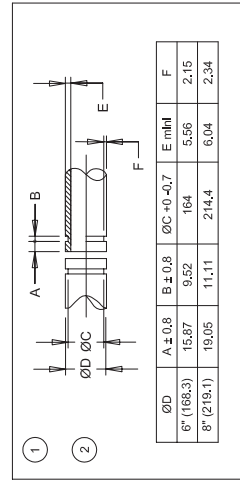

Dimensional Data

REFROIDISSEURS DE LIQUIDE / WASSERKUEHLMASCHINEN / LIQUID CHILLERS

①	CONNEXION ENTREE DEAU EVAPORATEUR	WASSER-EINTRITT-VERDAMPFER	EVAPORATOR WATER INLET CONNECTION
②	CONNEXION SORTIE DEAU EVAPORATEUR <td>WASSER-AUSTRITT-VERDAMPFER <td>EVAPORATOR WATER OUTLET CONNECTION</td> </td>	WASSER-AUSTRITT-VERDAMPFER <td>EVAPORATOR WATER OUTLET CONNECTION</td>	EVAPORATOR WATER OUTLET CONNECTION
③	ARMOIRE ELECTRIQUE <td>STEUERSCHRANK <td>ELECTRICAL PANEL</td> </td>	STEUERSCHRANK <td>ELECTRICAL PANEL</td>	ELECTRICAL PANEL
④	ACCES RACCORDEMENT CLIENTE - ALIMENTAZIONE PUNTA CLIENTE (155 x 400) <td>ABDECKPLATTE FÜR KUNDENANSCHLUSSE (155 x 400) <td>ACCESS PARA EL CABLEADO DE FUERZA A REALIZAR POR EL CLIENTE (155 x 400)</td> </td>	ABDECKPLATTE FÜR KUNDENANSCHLUSSE (155 x 400) <td>ACCESS PARA EL CABLEADO DE FUERZA A REALIZAR POR EL CLIENTE (155 x 400)</td>	ACCESS PARA EL CABLEADO DE FUERZA A REALIZAR POR EL CLIENTE (155 x 400)
⑤	POINT DE LEVAGE Ø45 <td>TRANSPORT-OESEN Ø45 <td>RINGING EYES Ø45</td> </td>	TRANSPORT-OESEN Ø45 <td>RINGING EYES Ø45</td>	RINGING EYES Ø45
⑥	MASSE EN FONCTIONNEMENT (kg) <td>BETRIEBSGEWICHT (kg) <td>OPERATING WEIGHT (kg)</td> </td>	BETRIEBSGEWICHT (kg) <td>OPERATING WEIGHT (kg)</td>	OPERATING WEIGHT (kg)
⑦	CHARGE DE FLUIDE FRIGORIGENE (kg) R134a <td>KÄLTEMITTEL-FÜLLUNG (kg) R134a <td>REFRIGERANT CHARGE (kg) R134a</td> </td>	KÄLTEMITTEL-FÜLLUNG (kg) R134a <td>REFRIGERANT CHARGE (kg) R134a</td>	REFRIGERANT CHARGE (kg) R134a
⑧	CHARGE D'HUILE (Litres) <td>ÖLFÜLLUNG (Liter) <td>OIL CHARGE (Litres)</td> </td>	ÖLFÜLLUNG (Liter) <td>OIL CHARGE (Litres)</td>	OIL CHARGE (Litres)
⑨	AIRÉ CONSEILLÉ POUR MAINTENANCE <td>MINDEST-WANDABSTAND (ZUR WARTUNG) <td>MINIMUM CLEARANCE (FOR MAINTENANCE)</td> </td>	MINDEST-WANDABSTAND (ZUR WARTUNG) <td>MINIMUM CLEARANCE (FOR MAINTENANCE)</td>	MINIMUM CLEARANCE (FOR MAINTENANCE)
⑩	AIRÉ CONSEILLÉ POUR DETUBAGE DE LEVAPORATEUR <td>MINDEST-WANDABSTAND (VERDAMPFER-AUSSAU) <td>MINIMUM CLEARANCE (EVAPORATOR TUBES REMOVAL)</td> </td>	MINDEST-WANDABSTAND (VERDAMPFER-AUSSAU) <td>MINIMUM CLEARANCE (EVAPORATOR TUBES REMOVAL)</td>	MINIMUM CLEARANCE (EVAPORATOR TUBES REMOVAL)
⑪	AIRÉ NECESSAIRE POUR ENTREE D'AIR <td>MINDEST WANDABSTAND (LUFT-EINTRITT) <td>MINIMUM CLEARANCE (AIR ENTERING)</td> </td>	MINDEST WANDABSTAND (LUFT-EINTRITT) <td>MINIMUM CLEARANCE (AIR ENTERING)</td>	MINIMUM CLEARANCE (AIR ENTERING)
⑫	ACCES RACCORDEMENT-CONTROLE ET REGULATION (3 PRESSE-ETOUPIES 2 PG13,5 + 1 PG9) <td>ABDECKPLATTE FÜR BAUSEITIGE STEUER- UND REGULATION (3 KABELVERSCHÄUBUNG 2 PG13,5 + 1 PG9) <td>EXTERNAL CONTROL WIRING CABLE GLAND FOR BAUSEITIGE STEUERUNG (3 KABELVERSCHÄUBUNG 2 PG13,5 + 1 PG9) </td></td>	ABDECKPLATTE FÜR BAUSEITIGE STEUER- UND REGULATION (3 KABELVERSCHÄUBUNG 2 PG13,5 + 1 PG9) <td>EXTERNAL CONTROL WIRING CABLE GLAND FOR BAUSEITIGE STEUERUNG (3 KABELVERSCHÄUBUNG 2 PG13,5 + 1 PG9) </td>	EXTERNAL CONTROL WIRING CABLE GLAND FOR BAUSEITIGE STEUERUNG (3 KABELVERSCHÄUBUNG 2 PG13,5 + 1 PG9)
⑬	PASSAGE PROPOSE POUR CONNEXIONS <td>EMPFOHLENE KALTWASSER-ROHRLEITUNGSFÜHRUNG <td>RECOMMENDED CHILLED WATER PIPEWORK LAYOUT </td></td>	EMPFOHLENE KALTWASSER-ROHRLEITUNGSFÜHRUNG <td>RECOMMENDED CHILLED WATER PIPEWORK LAYOUT </td>	RECOMMENDED CHILLED WATER PIPEWORK LAYOUT
⑭	SECTIONNEUR PUISSANCE <td>SCHALTSCHRANK HAUPTSCHALTER <td>POWER DISCONNECT SWITCH </td></td>	SCHALTSCHRANK HAUPTSCHALTER <td>POWER DISCONNECT SWITCH </td>	POWER DISCONNECT SWITCH
⑮	AMORTISSEURS <td>DAEMPFER <td>ISOLATORS </td></td>	DAEMPFER <td>ISOLATORS </td>	ISOLATORS

REFRIGERATO DI LIQUIDO / WATKOEELMACHINE / ENFRIADORA DE LIQUIDO

①	COLLEGAMENTO INGRESSO ACQUA	VERDAMPFER WATERINTREDE	CONEXION DE ENTRADA DE AGUA AL EVAPORADOR
②	COLLEGAMENTO USCITA ACQUA	VERDAMPFER WATERUITREDE	CONEXION DE SALIDA DE AGUA DEL EVAPORADOR
③	PANNELLO DI CONTROLLO	BESTURINGSPANEEL	PANEL DE CONTROL
④	ACCESO RACCORDI CLIENTE - ALIMENTAZIONE DI POTENZA (155 x 400)	BUNDOPLAAT TEN BEHOEVE VAN VOEDINGSKABEL KLANT (155 x 400)	ACCESO PARA EL CABLEADO DE FUERZA A REALIZAR POR EL CLIENTE (155 x 400)
⑤	GOLFARI Ø45	HUISOGEN Ø45	PUNTOS DE ELEVACION Ø45
⑥	PESO IN FUNZIONAMENTO (kg)	BETRIEFSGEWICHT (kg)	PESO EN OPERACION (kg)
⑦	CARICA DI FLUIDO FRIGORIGENO (kg) R134a	KOUDEMIDDELVULLING (kg) R134a	CARGA DE REFRIGERANTE (kg) R134a
⑧	CARICA D'OLIO (LH)	OLEVULLING (Litres)	CARGA DE ACEITE (Litros)
⑨	MINIMO SPAZIO DI SERVIZIO	MINIMUM VRIJLE RUIMTE (VOOR ONDERHOUD)	ESPACIO LIBRE (MINIMO PARA MANTENIMIENTO)
⑩	SPAZI MINIMI RICHIESTI PER LA RIMOZIONE TUBI EVAPORATORE	MINIMUMAFSTAND (VERVANGEN VERDAMPFER PIPEN)	ESPACIO LIBRE PARA EXTRA
⑪	SPAZIO PER ARIA IN ENTRATA	MINIMALE VRIJLE RUIMTE VOOR LUCHTINTREDE	ESPACIO LIBRE (MINIMO PARA TOMA DE AIRE)
⑫	ACCESO RACCORDI CLIENTE - ALIMENTAZIONE DI POTENZA (155 x 400) PRELIMISTOPPA 2 PG13,5 + 1 PG9)	BUNDOPLAAT TEN BEHOEVE VAN ALIMENTAZIONE CONTROLLO E REGOLA ZONE (3 WARTELS 2 PG13,5 + 1 PG9)	ACCESO RACCORDI CLIENTE-ALIMENTAZIONE CONTROLLO E REGOLA ZONE (3 PASSACABE 2 PG13,5 + 1 PG9)
⑬	COLLEGAMENTO IDRAULICO RACCOMANDATO	RECOMMENDED WATER LEIDINGSCOOP	DISTRIBUCION DE TUBERIAS DE AGUA FRIA RECOMENDADA
⑭	SEZIONATORE DI POTENZA	HOOFDSCHAKELAAR	SECTIONNADOR DE FUERZA
⑮	AMMORTIZZANTI	DEMPERS	AMORTIGUADORES

RTAC 120 - 200 50hz



RTAC	Dim.LxH	⑥ (kg)	⑦ (kg)	⑧ (L)	①	②
120HE	AL 7x3x5 ⁵ Cu, 2"	4481	75 + 75			
120XE	AL 7x3x5 ⁵ Cu, 2"	5085	77 + 77			
130HE	AL 7x3x5 ⁵ Cu, 2"	4519	79 + 75	4"		
130XE	AL 7x3x5 ⁵ Cu, 2"	4712	92 + 77			
140SE	AL 7x3x5 ⁵ Cu, 2"	4481	75 + 75			
140HE	AL 7x3x5 ⁵ Cu, 2"	4529	79 + 79			
140XE	AL 7x3x5 ⁵ Cu, 2"	4613	92 + 92	6 + 6	6"	
155SE	AL 7x3x5 ⁵ Cu, 2"	4639	79 + 75			
155HE	AL 7x3x5 ⁵ Cu, 2"	5100	98 + 93			
155XE	AL 7x3x5 ⁵ Cu, 2"	5351	114 + 96			
170SE	AL 7x3x5 ⁵ Cu, 2"	4794	79 + 79			
170HE	AL 7x3x5 ⁵ Cu, 2"	5431	98 + 98			
175XE	AL 7x3x5 ⁵ Cu, 2"	5942	119 + 96	8,5 + 6		
185SE	AL 7x3x5 ⁵ Cu, 2"	5386	98 + 95			6"
185HE	AL 7x3x5 ⁵ Cu, 2"	6079	102 + 98			
185XE	AL 7x3x5 ⁵ Cu, 2"	6307	119 + 99			
200SE	AL 7x3x5 ⁵ Cu, 2"	5488	98 + 98			
200HE	AL 7x3x5 ⁵ Cu, 2"	6117	102 + 102	8,5 + 8,5		
200XE	AL 7x3x5 ⁵ Cu, 2"	6497	119 + 119			

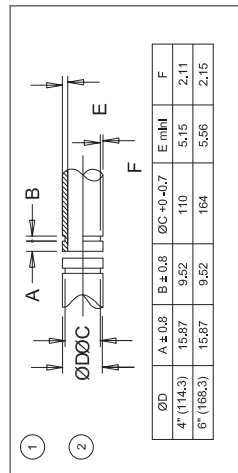

Dimensional Data

RTAC 120 - 200

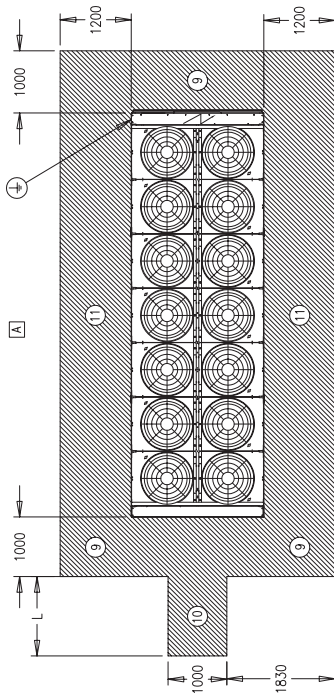

- Nombre de ventilateurs (J) voir plan implantation des composants
- Anzahl Lüfter (J) : siehe montageskizze der Komponenten
- Number of fans (J), refer to the component location drawing
- Numero di ventilatori (J), fare riferimento al documento Disposizione dei componenti
- Anzahl ventilatoren (J) : zie plaats van componenten
- Numero de ventiladores (J), ver dibujo de la localización de los componentes

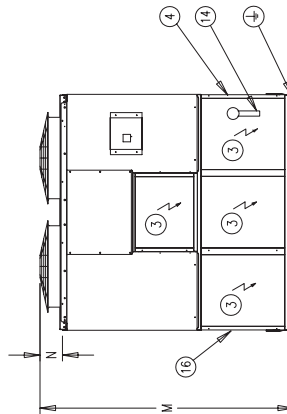
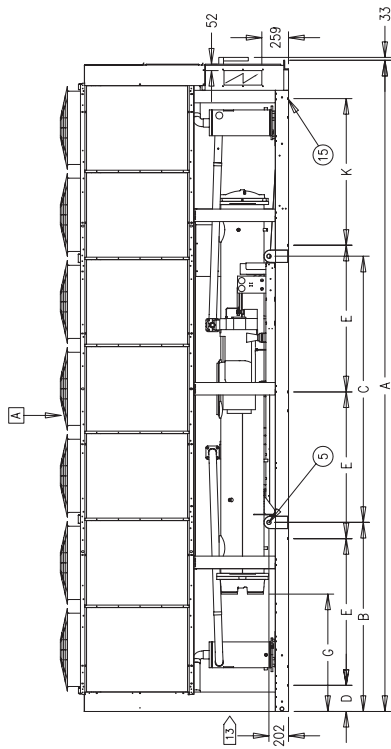

DIGIT 19	M	N
P (100 Pa Fans)	2381	182
X-L-Q (Other Fans)	2411	212

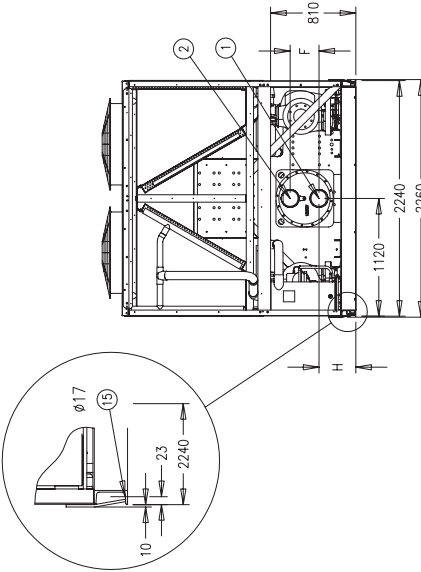

RTAC	A	B	C	D	E	F	G	H	J	K	L
120XE	5041	1439	2100	271	1456	252	524	291	8	-	1900
120HE-140SE	5041	1439	2100	271	1456	252	524	291	8	-	1900
130HE-155SE	5041	1439	2100	271	1456	252	524	291	9	-	1900
130XE	5041	1439	2100	271	1456	252	524	291	10	-	1900
140HE-140XE-170SE	5041	1439	2100	271	1456	274	505	350	10	-	1900
155HE-185SE	5960	1543	2812	273	1761	274	963	350	11	-	1500
155XE-170HE-200SE	5960	1543	2812	273	1761	274	963	350	12	-	1500
175XE-185HE	6879	1997	2812	275	1550	274	1242	350	13	1550	1600
185XE-200HE-200XE	6879	1997	2812	275	1550	274	1242	350	14	1550	1600

Mechanical Specifications

General

RTAC chillers

- Comply with EC requirements for Machinery, Electromagnetic and Pressure Equipment Directives (98/37/CE directive), as amended, and with national implementing legislation.
- Are designed and manufactured in accordance with the quality assurance ISO 9001/BS EN ISO9001.
- Are certified and rated in accordance with Eurovent standard.

Units are leak- and pressure-tested at 25 bars [360 psi] high side and 14 bars [200 psi] low side, and then evacuated and charged. Packaged units ship with a full operating charge of oil and refrigerant. Unit panels, structural elements, and control boxes are constructed of 1.5 to 3 mm [11 to 16 gauge] galvanized sheet metal and mounted on a welded structural-steel base. The unit panels, control boxes, and structural-steel base are finished with an air-dry paint RAL 9002.

Evaporator

The evaporator is a tube-in-shell heat exchanger design, with internally-finned copper tubes roller-expanded into the tube sheet. The evaporator is designed, tested, and stamped in accordance with the appropriate pressure-vessel code approval. The evaporator is designed for a waterside working pressure of 10.5 bars[200 psi]. Water connections are grooved pipe for Victaulic couplings. Each shell includes a vent, a drain, and fittings for temperature control sensors, and is insulated with 19mm [3/4 inch] Armaflex II (or equivalent) insulation (K=0.26).

Condenser and Fans

Air-cooled condenser coils have aluminum fins mechanically bonded to internally-finned seamless copper tubing. The condenser coil has an integral subcooling circuit. Condensers are factory proof- and leak-tested at 35 bars [500 psi]. Direct-drive vertical-discharge airfoil condenser fans are dynamically

balanced. Three-phase condenser fan motors with permanently-lubricated ball bearings are provided. Standard units will start and operate from 0 to 46°C [32 to 115°F] ambient. (High ambient option above 40°C).

Compressor and Lube Oil System

The helical-rotary compressor is semi-hermetic, direct drive, 3000 rpm, with capacity-control slide valve, a load/unload valve, rolling element bearings, differential refrigerant pressure oil pump, and oil heater. The motor is a suction-gas-cooled, hermetically sealed, two-pole squirrel-cage induction design. Oil separator and filtration devices are provided separate from the compressor. Check valves in the compressor discharge and lube oil system, and a solenoid valve in the lube system (manifolded compressor only), are provided.

Refrigeration Circuits

Each unit has two refrigerant circuits, with one or two helical-rotary compressors per circuit. Each refrigerant circuit includes a mechanical filter, liquid-line shutoff valve, liquid-line sight glass, charging port, and an electronic expansion valve. Fully modulating compressors and electronic expansion valves provide variable capacity modulation over the entire operating range. (Optional compressor suction service valve).

Mechanical Specifications

Unit Controls

All unit controls are housed in a weather-tight enclosure, with removable plates to allow for customer connection of power wiring and remote interlocks. All controls, including sensors, are factory-mounted and tested prior to shipment. Microcomputer controls provide all control functions including startup and shutdown, leaving-chilled-water temperature control, compressor and electronic expansion-valve modulation, fan sequencing, anti-recycle logic, automatic lead/lag compressor starting, and load limiting. The unit control module, utilizing the Adaptive Control™ microprocessor, automatically takes action to avoid unit shutdown due to abnormal operating conditions associated with low refrigerant pressure, high condensing pressure, and motor current overload. Should the abnormal operating condition continue until a protective limit is violated, the unit will be shut down. Unit protective functions include loss of chilled-water flow, evaporator freezing, loss of refrigerant, low refrigerant pressure, high refrigerant pressure, reverse rotation, compressor-starting and running overcurrent, phase loss, phase imbalance, phase reversal, and loss of oil flow. The Dyna View digital display indicates the chilled-water set point and the leaving-chilled-water temperature. In addition, the display indicates the current limit set point, the evaporator and condenser refrigerant pressures, and electrical information. The display can be viewed on the unit without opening any control panel doors. Standard power connections include main three-phase power to the compressors, condenser fans, control power transformer, and freeze protection on the evaporator heaters.

Starters

Starters are housed in a weather-tight enclosure with hinged doors to allow for customer connection of power wiring. Wye-Delta closed transition starters (33% of LRA inrush) are standard.

Notes



TRANE®

Cooling and Heating
Systems and Services



LONMARK®
SPONSOR

Literature Order Number	RLC-PRC005-E4
Date	0110
Supersedes	RLC-PRC005-E4_0409

Trane has a policy of continuous product and product data improvement and reserves the right to change design and specifications without notice. Only qualified technicians should perform the installation and servicing of equipment referred to in this publication.

www.trane.com

For more information, contact your local
sales office or e-mail us at comfort@trane.com

Trane bvba
Lenneke Marelaan 6 - 1932 Sint-Stevens-Woluwe, Belgium
ON 0888.048.262 - RPR BRUSSELS